

ECOFLEX

Mini VRF



Discreet yet powerful solution
for both homes and businesses.



actronair.com.au

ACTRONAIR.

Australia needs Australian Air conditioning

Australian-Owned & Operated

Since 1984, ActronAir has been committed to offering air conditioning systems that reflect the essence of Australian craftsmanship. Our systems are thoughtfully designed and carefully manufactured in Australia, featuring unique customisations to effectively address the diverse climate conditions found within the country.

Trusted by Thousands

At ActronAir, we have built a strong and enduring reputation through years of dedication and excellence, earning the trust of countless customers across Australia. Our commitment to quality, reliability, and performance has made us the preferred choice.

Innovation at Its Core

Innovation is central to ActronAir's identity, as we continuously invest in research and development to maintain a leading-edge position in technology, driving advancements in our air conditioning solutions.

Tailored Solutions

We recognise the uniqueness of each space and offer a broad range of customised air conditioning solutions to cater to various specific needs and preferences. We emphasise the importance of providing tailored solutions to meet the unique requirements of different environments.

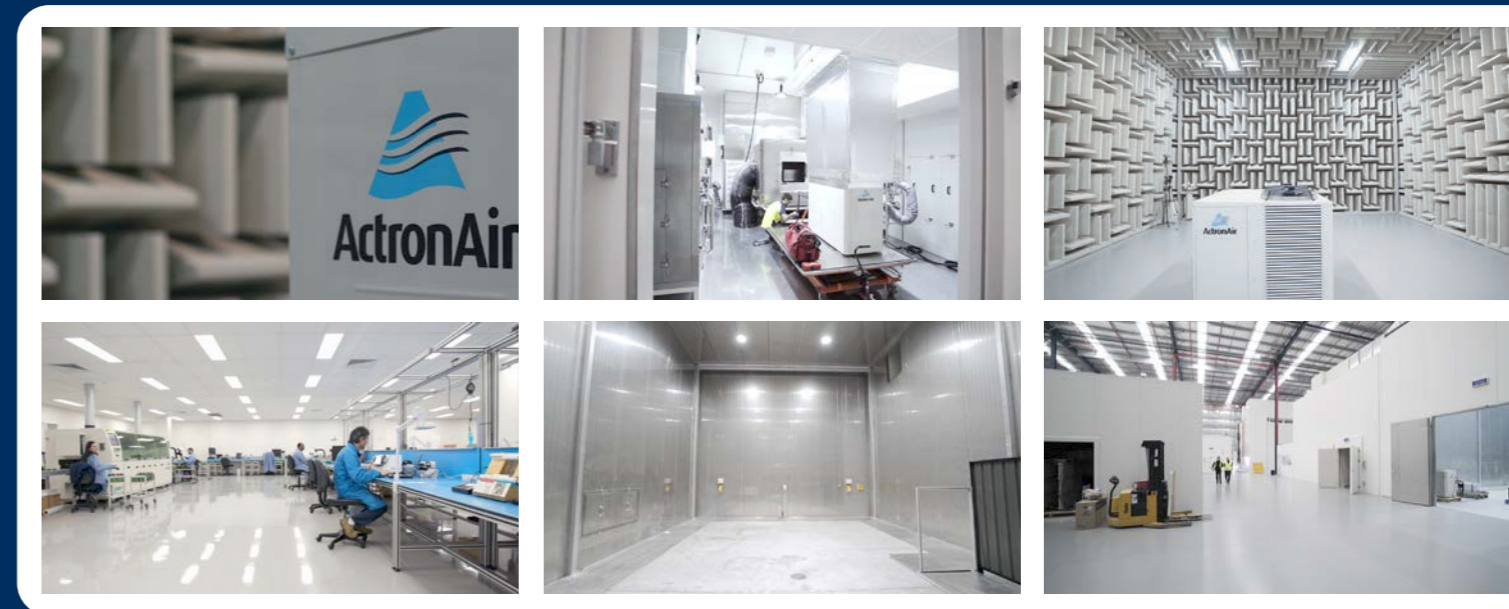

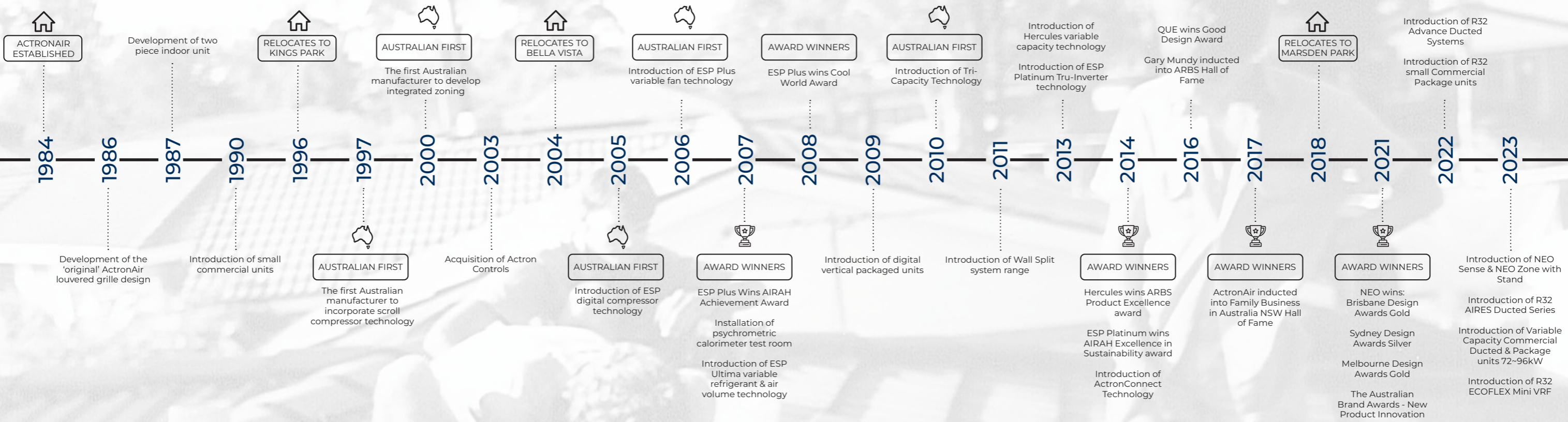

EVOLUTION.

Designing and building Since 1984.

Introducing ECOFLEX MINI VRF

Introducing **ECOFLEX** Mini VRF to ActronAir's product portfolio, a discreet yet powerful solution for both homes and businesses. This Variable Refrigerant Flow (VRF) system is a game-changer in indoor climate control. By intelligently optimising heating and cooling operations, it not only saves energy but also reduces your environmental impact.

What makes the **ECOFLEX** Mini VRF truly stand out is its ability to deliver personalised comfort through flexible zoning. It adjusts temperature and air distribution in individual spaces, ensuring efficiency by conditioning only where needed the most. Designed for tranquillity, this system operates quietly, making it ideal for bedrooms, living areas, and workspaces.

But that's not all - the **ECOFLEX** Mini VRF seamlessly integrates into building management systems. With user-friendly controls and remote monitoring capabilities, you can effortlessly manage your indoor environment. ActronAir's commitment to sustainability is evident in this system's use of eco-friendly, low GWP R32 refrigerant.

Experience elevated indoor comfort with ActronAir's **ECOFLEX** Mini VRF - a blend of efficiency and flexibility that sets standards for air conditioning.

Creating Comfort

At ActronAir, we believe in creating comfortable living spaces that enhance the quality of life. **ECOFLEX** Mini VRF, a versatile system designed to meet the unique requirements of different living areas. With a range of outdoor units, indoor units, and control devices, this system brings satisfaction to homeowners while providing numerous advantages to architects, installers, and space designers.



Adaptability



Design Flexibility



Comfort



Easy Installation



Performance



Controls Integration



OUTDOORS.

Tailored capacities, optimal performance, elevating energy efficiency with ECOFLEX Mini VRF.

With a range of capacities to choose from, these units are tailored to meet the specific needs of different buildings, ensuring optimal performance and energy savings.

INDEX

8	Overview
10	Technology
12	Efficiency
14	Flexibility
16	Safety
18	Installation
20	Specifications



OVERVIEW.

The perfect blend of compactness and capacity.

With smaller outdoor units that traditional larger VRF systems this series offers unmatched flexibility during installation. Don't let its size fool you, as it delivers exceptional performance for all your cooling and heating needs.

DC Components

ECOFLEX Mini VRF series capitalises on a suite of advanced technologies, including DC inverter compressor, DC electronic control boards, and DC outdoor fan motor. These advanced components synergise to enable precise and continuous speed adjustments, precisely aligning the system's operation with real-time requirements.

Wide Operation Range

ECOFLEX Mini VRF systems are made for Australian weather conditions, which can exceed temperatures of 46°C. Unlike most overseas air conditioners with a maximum operating temperature range of up to 46°C, ECOFLEX Mini VRF systems can operate across a wide spectrum, spanning from -20°C to 52°C.

R32 Refrigerant

ActronAir is environmentally aware and considers the potential impact and cost effectiveness of the refrigerants it uses. That's why ECOFLEX Mini VRF utilises R32, with a substantially lower Global Warming Potential than some alternative refrigerants, while enjoying the benefits of optimised energy efficiency.

Intelligent Systems

With its advanced self-learning capabilities, these systems constantly analyse operating parameters to optimise performance. By utilising smart algorithms, the systems will always operate at its peak efficiency, ensuring comfort and cost savings for years to come.

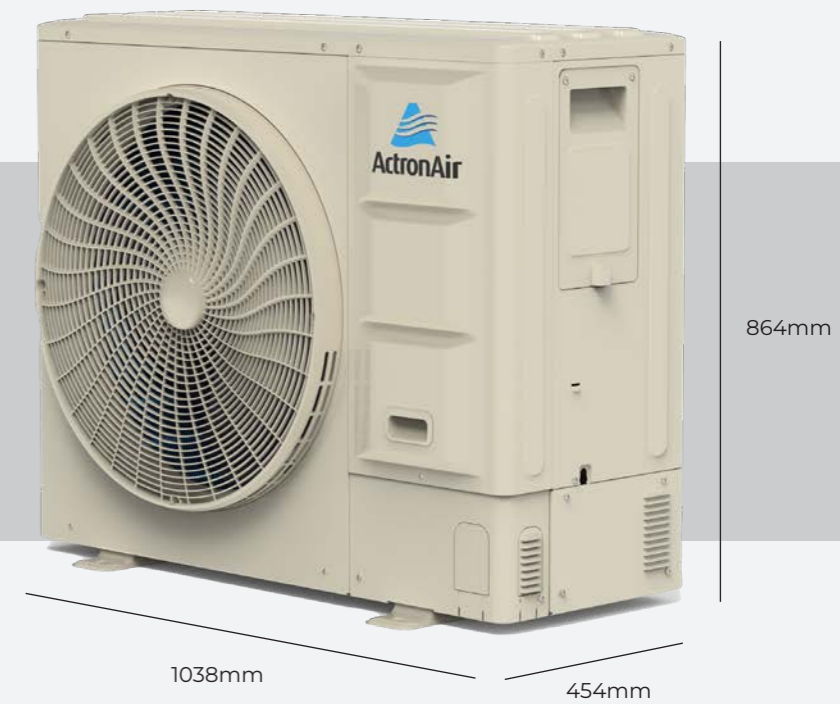

Summary

		Units	ECOFLEX Series
Capacity	Nominal Cooling	kW	7.2 ~ 17.5
	Nominal Heating	kW	7.2 ~ 17.5
Connectable indoor unit quantity		unit	2 ~ 12
Combination capacity ratio between ODU and IDU		%	50 ~ 160
Maximum piping length	Total piping length	m	150 ~ 300
	Between 1st branch kit and farthest indoor unit	m	30 ~ 40
	Vertical Height between ODU and IDU (ODU above IDU)	m	30 ~ 50
	Vertical Height between ODU and IDU (IDU above ODU)	m	20 ~ 40
	Between indoor units	m	15



TECHNOLOGY.

Arbitrary Topology Communication

In addition to the traditional daisy chain connection, the communication wire supports alternative configurations like tree connection, star connection, ring connection, and more. The wiring is flexible, significantly reducing installation costs and eliminating the possibility of on-site connection errors.

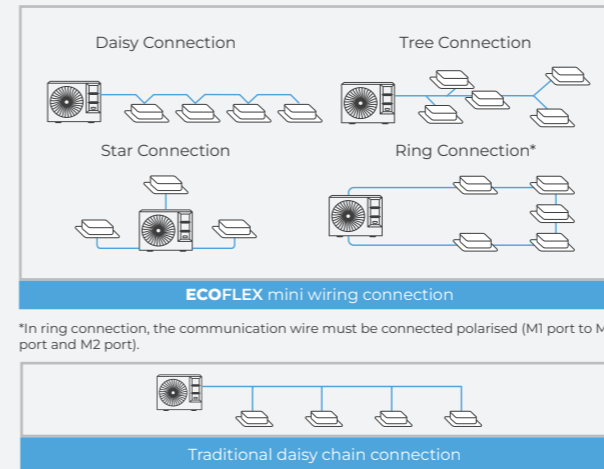

Condition Sensors

The ECOFLEX Mini VRF is equipped with as many as 13 condition sensors, each featuring built-in data models for essential components such as compressors, heat exchangers, and throttling components. This advanced system excels in real-time analysis of sensor data, enabling it to discern the status of the refrigerant at any point within the system.



HyperLink Communication

The HyperLink communication technology accommodates various wiring patterns, not limited to the daisy chain connection. This helps cut down installation costs and lowers the likelihood of incorrect connections.

Anti-interference Capability

ECOFLEX Mini VRF systems feature special waveform restoration technology, boosting anti-interference performance for exceptionally stable communication of distances of up to **2000m**.

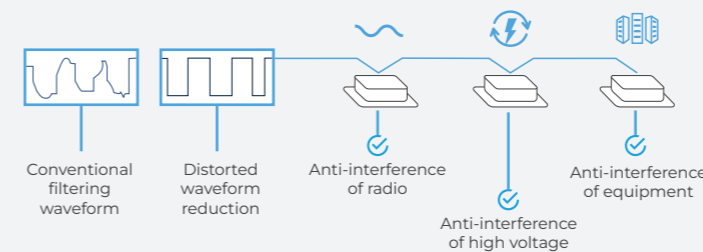

Virtual Sensor Backup

By employing digital algorithms, each physical sensor creates a corresponding virtual sensor, serving as a redundant counterpart. This redundancy guarantees that the system's functionality remains unaffected even if one of the sensors encounters a failure.



EFFICIENCY.

60-Step Energy Management

In scenarios where projects face temporary constraints on electricity supply, the outdoor unit offers a robust 60-step energy management feature. This functionality allows precise control over the unit's output capacity, which can be adjusted in increments as small as 1%. This level of control serves a dual purpose: it prevents the system from tripping or shutting down when confronted with electricity supply restrictions and ensures uninterrupted system operation.

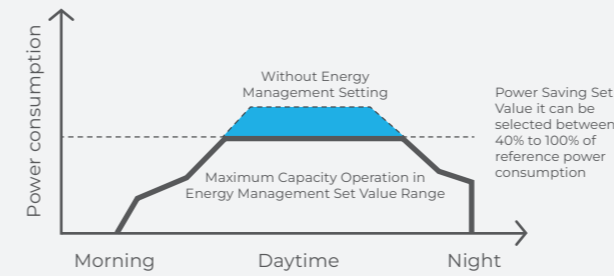

Low Standby Power Consumption

In contrast to the standby power consumption of approximately 30W in traditional VRF systems, the **ECOFLEX** Mini VRF employs an optimized control scheme, effectively lowering standby power consumption to as minimal as 3.5W.

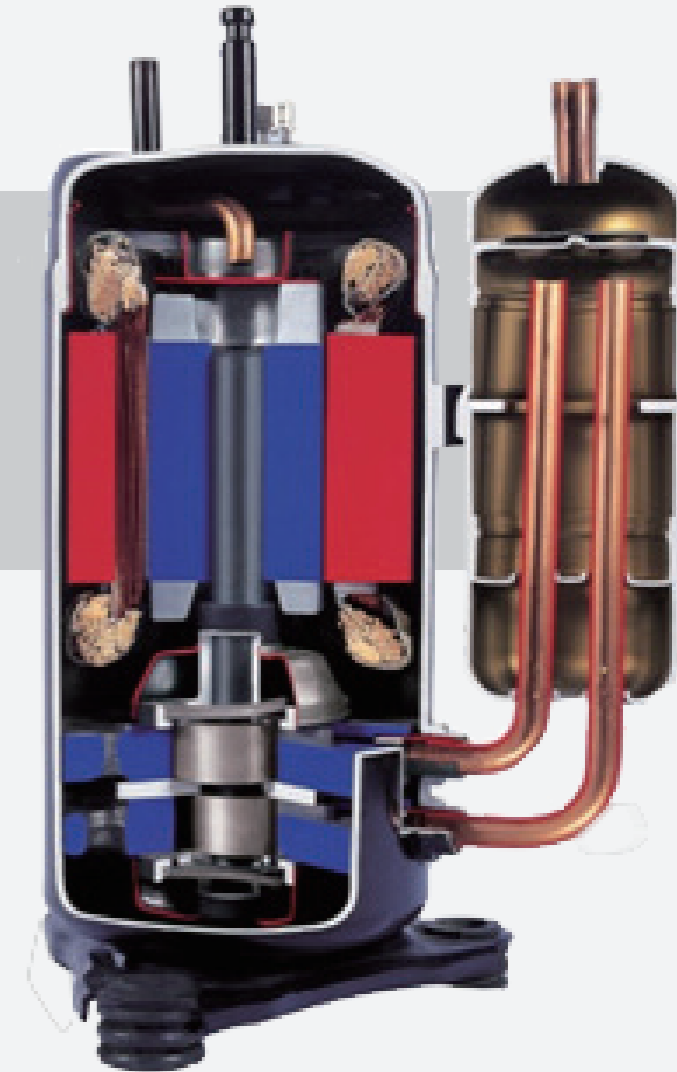
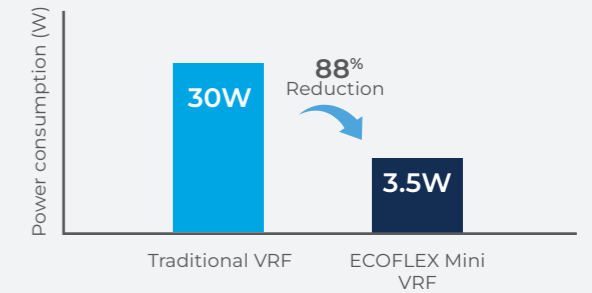

Advanced Subcooling Technology

The **ECOFLEX** Mini VRF incorporates a plate heat exchanger to enhance refrigerant cooling, allowing the refrigerant system to achieve a 15°C refrigerant subcooling. This not only enhances refrigerant heat transfer efficiency but also reduces the noise associated with refrigerant flow.

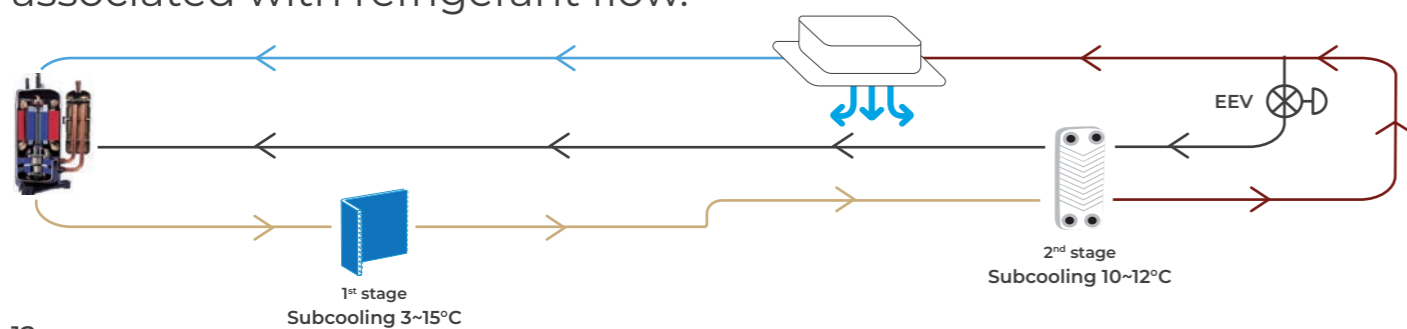

Full DC Inverter Technology

ECOFLEX Mini VRF systems employ a full DC inverter compressor for precise and continuous speed adjustments based on system operation. This feature guarantees that the system consistently operates at its optimal condition, resulting in enhanced efficiency and reduced noise levels.

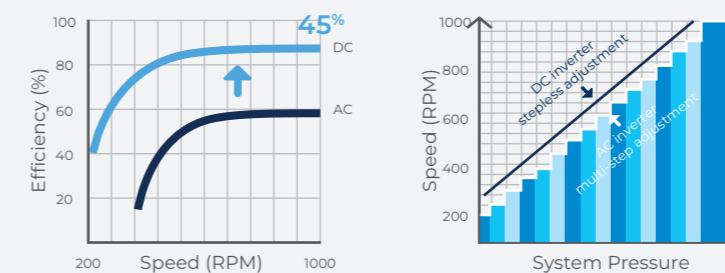



FLEXIBILITY.

Wide Combination Ratio

In contrast to the conventional Mini VRF systems with a combination ratio of 50-130%, the **ECOFLEX Mini VRF** extends this range to 50-160%. This broader combination ratio facilitates a more flexible system configuration, particularly advantageous for long-term part-load operation scenarios. This adaptability not only enhances system efficiency but also contributes to a reduction in installation costs.

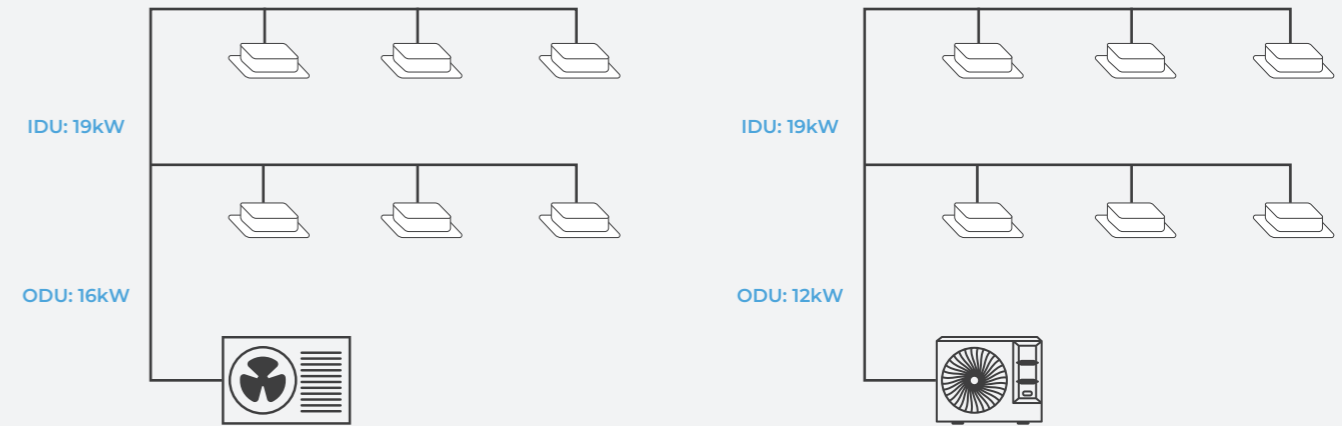

Wide Range of Indoor Units

The **ECOFLEX Mini VRF** system provides a versatile solution with a selection of 11 distinct indoor units designed to cater to a wide range of application scenarios, including but not limited to homes, offices, villas, and restaurants. This variety of indoor units not only ensures compatibility with diverse environments but also offers several notable benefits such as space optimisation, zoning control and meeting decor needs.



Long Piping Capability

ECOFLEX Mini VRF systems are designed for small and medium-sized buildings, with a total piping length capability of up to 300m. It accommodates a level difference of up to 50m between indoor and outdoor units and up to 15m between indoor units, making it well-suited for a variety of building configurations.

Piping length / Height difference		Capability (m)	
		8-10kW	12-18kW
Total piping length		150	300
1. Longest piping length	Actual	50	100
	Equivalent	60	120
2. Longest piping length after first branch		30	40
3. Largest level difference between IDUs and ODU	ODU up	30	50
	ODU down	20	40
4. Largest level difference between IDUs		15	15

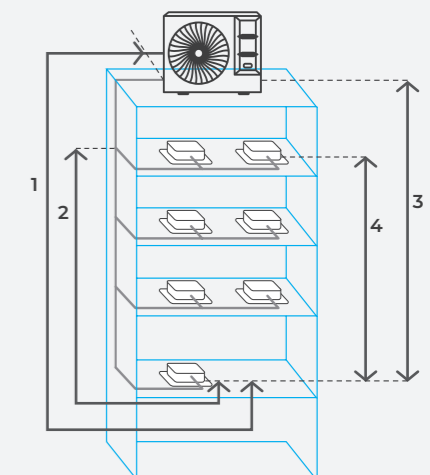



PROTECTION.

Automatic Refrigerant Recycling

The ECOFLEX Mini VRF system features an intelligent design aimed at improving maintenance and system reliability. This is made possible by a dual-mode refrigerant recycling system, enabling the smooth redirection of refrigerant flow when servicing.

Indoor units are equipped with EXVs to facilitate refrigerant recycling. After the indoor unit completes the recycling process, the EXV closes to isolate the indoor unit from the system.

On the outdoor side, refrigerant recycling function is contingent upon the compressor's operational status. If the compressor has failed, this feature remains inactive, ensuring a judicious use of the system's capabilities.

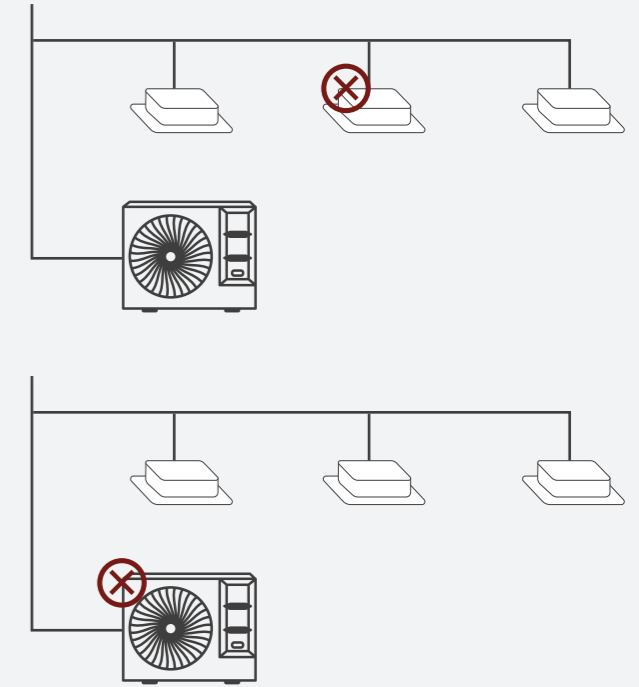

Precise Oil Control

A three-stage oil control technology is applied to consistently keep the outdoor compressor's oil at a safe level, effectively eliminating concerns regarding compressor oil shortages.

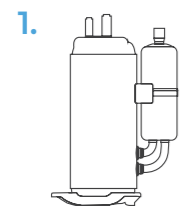

1. Compressor internal oil separation.

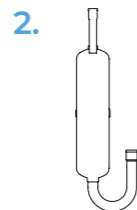

2. High-efficiency centrifugal oil separator (with separation efficiency of up to 99%) ensures that oil is separated from the discharge gas and returned to the compressors in a timely fashion.

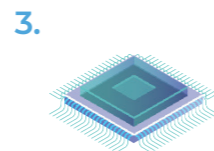

3. The automatic oil return program determines the oil return through the running time and the oil discharge amount, enabling precise oil return.

Refrigerant Shut-Off Device*

The shut-off device, located on the outdoor unit, is designed to automatically recover refrigerant in the event of a leakage, ensuring the safe containment of the refrigerant within the outdoor unit.

* Optional item, sold separately



Refrigerant Leak Sensor*

The refrigerant leak sensor is positioned on the indoor unit to identify any refrigerant leaks and can automatically trigger alarm measures for prompt response.

* Optional item, sold separately





INSTALLATION.

Auto Addressing

The **ECOFLEX** Mini system can automatically assign addresses for all indoor units, streamlining the installation process for added simplicity.

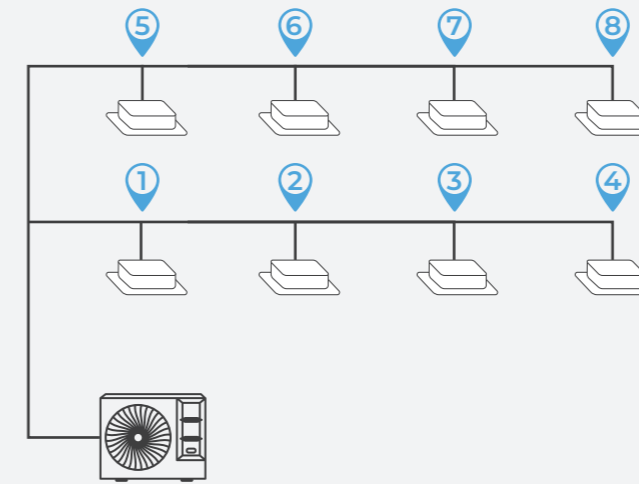

Flexible Pipe Connection

A four-directional space is provided for connecting pipes and wiring at different installation sites, offering added flexibility for the installer.

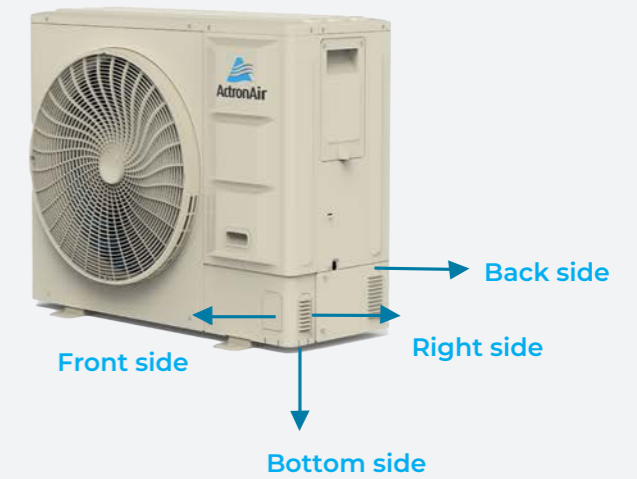

Ease of Transportation

The outdoor units' compact size facilitates effortless transport, making them well-suited for elevator transportation in diverse installation settings. This attribute provides a significant advantage, especially in scenarios with limited space or challenging access. The outcome is an installation process that is not only more efficient and streamlined but also enables faster project completion and reduced labour costs.

High External Pressure of Outdoor Unit

The system provides a robust solution with high external static pressure capabilities, reaching up to 35Pa. This capacity for high external static pressure not only enhances the overall performance and longevity of the outdoor unit but also underscores the system's adaptability to different installation scenarios, making it a reliable choice for diverse applications.



Technical Specifications - Outdoors

SINGLE PHASE

Model			MMV-080CS	MMV-100CS	MMV-120CS
Power Supply		V / N / Hz	220-240V / 1PH / 50Hz		
Cooling	Capacity (Rated)	kW	8.00	10.00	12.00
	Power Input (Rated)	kW	2.24	3.00	3.30
	EER		TBC	3.42	TBC
	Seasonal Performance Factor	TCSPF (Hot / Mixed / Cold)	TBC	TBC	TBC
Heating	Capacity (Rated)	kW	9.00	12.00	14.00
	Power Input (Rated)	kW	2.24	3.26	3.30
	COP		TBC	3.67	TBC
	Seasonal Performance Factor	HSPF (Hot / Mixed / Cold)	TBC	TBC	TBC
Indoor Connections	No. of Indoor Units		5	6	8
	Connection Ratio		50 ~ 160%		
Compressor	Type / Quantity		DC Inverter / 1		
	Start up Method		Soft Start		
Fan Motor	Type		DC / 1		
	Static Pressure	Pa	0 - 35		
Refrigerant	Type		R32		
	Factory Change		2.00	2.00	2.85
Pipe Connections	Liquid Pipe	mm	9.5	9.5	9.5
	Gas Pipe	mm	15.9	15.9	15.9
Sound Pressure Level		dB (A)	53	53	55
Sound Power Level		dB (A)	68	69	70
Dimensions	W x H x D	mm	1038 x 864 x 409		
Weight		kg	77		94
Operating Range	Cooling	°C(DB)	-15 to 52°C		
	Heating	°C(DB)	-20 to 16.5°C		

THREE PHASE

Model			MMV-120CT	MMV-140CT	MMV-160CT	MMV-180CT
Power Supply		V / N / Hz	380-415V / 3PH / 50Hz			
Cooling	Capacity (Rated)	kW	12.00	14.00	15.50	17.50
	Power Input (Rated)	kW	3.37	4.67	5.34	6.46
	EER		TBC	TBC	TBC	TBC
	Seasonal Performance Factor	TCSPF (Hot / Mixed / Cold)	TBC	TBC	TBC	TBC
Heating	Capacity (Rated)	kW	14.00	16.00	18.00	19.50
	Power Input (Rated)	kW	2.86	3.29	3.73	4.49
	COP		TBC	TBC	TBC	TBC
	Seasonal Performance Factor	HSPF (Hot / Mixed / Cold)	TBC	TBC	TBC	TBC
Indoor Connections	No. of Indoor Units		8	10	11	12
	Connection Ratio		50 ~ 160%			
Compressor	Type		DC Inverter / 1			
	Start up Method		Soft Start			
Fan Motor	Type		DC / 1			
	Static Pressure	Pa	0 - 35			
Refrigerant	Type		R32			
	Factory Change		2.85	2.85	2.85	2.85
Pipe Connections	Liquid Pipe	mm	9.5	9.5	9.5	9.5
	Gas Pipe	mm	15.9	15.9	15.9	19.1
Sound Pressure Level		dB (A)	55	56	56	58
Sound Power Level		dB (A)	70	71	72	73
Dimensions	W x H x D	mm	1038 x 864 x 409			
Weight		kg	110	110	110	110
Operating Range	Cooling	°C(DB)	-15 to 52°C			
	Heating	°C(DB)	-20 to 16.5°C			

Model			MMV-140CS	MMV-160CS	MMV-180CS
Power Supply		V / N / Hz	220-240V / 1PH / 50Hz		
Cooling	Capacity (Rated)	kW	14.00	15.50	17.50
	Power Input (Rated)	kW	4.12	4.60	5.53
	EER		TBC	TBC	TBC
	Seasonal Performance Factor	TCSPF (Hot / Mixed / Cold)	TBC	TBC	TBC
Heating	Capacity (Rated)	kW	16.00	18.00	19.50
	Power Input (Rated)	kW	3.86	4.50	4.93
	COP		TBC	TBC	TBC
	Seasonal Performance Factor	HSPF (Hot / Mixed / Cold)	TBC	TBC	TBC
Indoor Connections	No. of Indoor Units		10	11	12
	Connection Ratio		50 ~ 160%		
Compressor	Type / Quantity		DC Inverter / 1		
	Start up Method		Soft Start		
Fan Motor	Type		DC / 1		
	Static Pressure	Pa	0 - 35		
Refrigerant	Type		R32		
	Factory Change		2.85	2.85	2.85
Pipe Connections	Liquid Pipe	mm	9.5	9.5	9.5
	Gas Pipe	mm	15.9	15.9	19.1
Sound Pressure Level		dB (A)	56	56	58
Sound Power Level		dB (A)	71	72	73
Dimensions	W x H x D	mm	1038 x 864 x 409		
Weight		kg	94	94	94
Operating Range	Cooling	°C(DB)	-15 to 52°C		
	Heating	°C(DB)	-20 to 16.5°C		

Foot Notes:

1. Indoor temperature 27°C DB, 19°C WB; outdoor temperature 35°C DB; equivalent refrigerant piping length 5m with zero level difference.
2. Indoor temperature 20°C DB; outdoor temperature 7°C DB; equivalent refrigerant piping length 5m with zero level difference.
3. Sound level: Anechoic chamber conversion value, measured at a point of 1m in front of the unit at a height of 1m.
4. The above data may change without prior notice.



INDOORS.

Upgrade your living space with **ECOFLEX Mini VRF**.

The **ECOFLEX Mini VRF** provides a range of indoor units in its lineup, ensuring adaptable air conditioning that suits diverse applications and spatial configurations.

INDEX

24	Overview
26	Indoor Unit Line-Up
27	Feature Comparison
28	Specifications



OVERVIEW.

Experience efficient air conditioning tailored to your needs with ECOFLEX Mini VRF Indoors.

ECOFLEX Mini VRF Indoors offers precise climate control with a compact design. With intuitive controls, it adapts seamlessly to various living spaces, ensuring optimal comfort. The ultra-thin body design, integrated C-shaped heat exchangers, and efficient drainage simplify installations.

Indoor Temperature Detection Control

A chosen indoor unit can act as a central point to collect indoor temperatures from various indoor units. This centralised information allows for consistent control of multiple indoor units in a larger space, ensuring uniform temperature management. This approach enhances efficiency and precision in maintaining a comfortable indoor environment throughout the designated area.

Self-Cleaning Heat Exchanger

The self-cleaning process involves using freezing frost to solidify and break down dirt on the heat exchanger, followed by high-temperature sterilization to eliminate any remaining impurities. This combination enhances efficiency, ensuring a thorough and effective cleaning for optimal performance and hygiene.

EEV Automatic Adjustments

In heating standby mode, the indoor unit of the system adjusts the opening of the EEV according to the load it is handling. This intelligent adjustment aims to minimise the noise produced by the flow of refrigerant, ensuring a quieter and more comfortable environment enhancing the overall user experience during heating standby periods.

Cold Air Prevention

Upon initiation of the warming process, the fan speed automatically adjusts based on the coil temperature to prevent the discharge of cold air. Once the warm-up is complete, the fan speed will operate at the desired level.









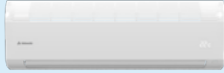

0.5°C / 1°C Setting Temperature Adjustment

This feature allows users to adjust the desired temperature with precision, offering flexibility in increments of either 0.5°C or 1°C. This level of control ensures that individuals can tailor the indoor climate according to their specific comfort preferences, contributing to a more personalised and responsive heating or cooling experience.

Auto Cooling-Heating Changeover

The system can autonomously determine whether to activate the cooling or heating mode based on the selected temperature setting. This automatic mode selection optimises energy efficiency and ensures that the indoor environment is consistently maintained at the desired temperature without manual adjustments. It simplifies the user experience and enhances the system's adaptability to changing temperature needs.

Indoor Unit Line-Up

Indoor Unit Category	(kW)	1.5	1.8	2.2	2.8	3.6	4.5	5.6	7.1	8.0	9.0	1.0	11.2	14.0	16.0	
High Wall MHW-XXXCS		●	●													
Compact 4-Way Cassette MCC-XXXCS		●	●													
4-Way Cassette MFC-XXXCS		●														
1-Way Cassette MOC-XXXCS		●														
2-Way Cassette MTC-XXXCS		●														
Slim Duct MSD-XXXCS		●	●													
MSP Concealed Duct MMD-XXXCS		●	●													
HSP Concealed Duct MHD-XXXCS		●														
Floor Standing Front Air Intake / Console MFF-XXXCS		●														

Features Comparison

	High Wall	Compact 4-Way Cassette	4-Way Cassette	1-Way Cassette	2-Way Cassette	Slim Duct	MSP Duct	HSP Duct	Floor Standing / Console
Quiet Operation	●	●	●	●	●	●	●	●	●
Auto Cooling-Heating change-over	●	●	●	●	●	●	●	●	●
Cold air prevention	●	●	●	●	●	●	●	●	●
Digital display on/off	●	●	●	●	●	●	●	●	●
Buzzer sound on/off	●	●	●	●	●	●	●	●	●
EEV automatic adjustment	●	●	●	●	●	●	●	●	●
Indoor temperature detection control	●	●	●	●	●	●	●	●	●
0.5°C or 1°C Setting temperature adjustment	●	●	●	●	●	●	●	●	●
Home leave mode	●	●	●	●	●	●	●	●	●
Sleep mode	●	●	●	●	●	●	●	●	●
Mildew proof of heat exchanger	●	●	●	●	●	●	●	●	●
Air filter	●	●	●	●	●	●	●	●	●
Fresh air intake	●	●	●	●	●	●	●	-	-
Visualisation of dirty blockage rate	-	-	-	-	-	●	●	●	-
Heat exchanger self-cleaning	●	●	●	●	●	●	●	●	●
Vertical swing	5 steps + auto	5 steps + auto	5 steps + auto	5 steps + auto	5 steps + auto	-	-	-	5 steps + auto
Fan speed steps	7 steps	7 steps	7 steps	7 steps	7 steps	7 steps	7 steps	7 steps	7 steps
Auto fan speed	●	●	●	●	●	●	●	●	●
Individual louvre controls	-	●	●	-	-	-	-	-	-
Soft wind mode	●	●	●	●	●	●	●	-	●
Adaptive ESP	-	-	-	-	-	●	●	●	-
Eco Mode	●	●	●	●	●	●	●	●	●
Full DC electronic components	●	●	●	●	●	●	●	●	●
High lift drain pump	-	●	●	●	●	●	●	●	-
Water level switch	-	●	●	●	●	●	●	●	-
Ceiling anti-dirt setting	●	●	●	-	-	●	●	●	-
2-core non-polarity communication wiring	●	●	●	●	●	●	●	●	●
Long communication wiring	●	●	●	●	●	●	●	●	●

Technical Specifications - High Wall

Model		MHW-015CS	MHW-022CS	MHW-028CS	MHW-035CS
Indoor Unit Power Supply		220-230V / 1PH / 50Hz			
Nominal Cooling Capacity		kW 1.50	2.20	2.80	3.60
Nominal Heating Capacity		kW 1.70	2.40	3.20	4.00
Airflow Range (H / L)		l/s 128 / 94	139 / 94	150 / 94	161 / 94
Dimensions Indoor (H x W x D)		mm 295 x 750 x 265	295 x 750 x 265	295 x 750 x 265	295 x 750 x 265
Weight		kg 9	9	10	10
Sound Pressure Level		H / L dBA 32 / 27	33 / 27	35 / 28	37 / 28
Sound Power Level		H / L dBA 45 / 40	46 / 40	50 / 42	54 / 44
Refrigerant Piping		Liquid Line mm 6.35	6.35	6.35	6.35
		Gas Line mm 12.7	12.7	12.7	12.7
Drain Pipe		mm OD 16			

Technical Specifications - High Wall

Model		MHW-045CS	MHW-056CS	MHW-071CS	MHW-080CS
Indoor Unit Power Supply		220-230V / 1PH / 50Hz			
Nominal Cooling Capacity		kW 4.50	5.60	7.10	8.00
Nominal Heating Capacity		kW 5.00	6.30	8.00	9.00
Airflow Range (H / L)		l/s 200 / 114	239 / 114	TBC	TBC
Dimensions Indoor (H x W x D)		mm 295 x 950 x 265	295 x 950 x 265	295 x 1200 x 265	295 x 1200 x 265
Weight		kg 11.5	11.5	15	15
Sound Pressure Level		H / L dBA 37 / 29	41 / 29	44 / 32	45 / 32
Sound Power Level		H / L dBA 54 / 44	56 / 44	58 / 46	60 / 46
Refrigerant Piping		Liquid Line mm 6.35	6.35	9.52	9.52
		Gas Line mm 12.7	12.7	15.9	15.9
Drain Pipe		mm OD 16			

Technical Specifications - 1-Way Cassette

Model		MOC-018CS	MOC-022CS	MOC-028CS	MOC-036CS	MOC-045CS	MOC-056CS	MOC-071CS
Indoor Unit Power Supply		220-230V / 1PH / 50Hz						
Nominal Cooling Capacity		kW 1.80	2.20	2.80	3.60	4.50	5.60	7.10
Nominal Heating Capacity		kW 2.20	2.60	3.20	4.00	5.00	6.30	8.00
Airflow Range (H / L)		l/s 106 / 67	106 / 67	128 / 83	128 / 83	193 / 132	220 / 153	259 / 164
Dimensions (H x W x D)		Indoor mm 153 x 1054 x 428			189 x 1275 x 452			
		Panel mm 25 x 1180 x 465			25 x 1350 x 505			
Weight		Indoor kg 11.5	11.5	11.8	11.8	15.8	15.8	16.9
		Panel kg 3.5	3.5	3.5	3.5	4	4	4
Sound Pressure Level		H / L dBA 30 / 22	30 / 22	37 / 30	38 / 30	39 / 31	41 / 33	43 / 35
Refrigerant Piping		Liquid Line mm 6.35	6.35	6.35	6.35	6.35	6.35	9.52
		Gas Line mm 12.7	12.7	12.7	12.7	12.7	12.7	15.9
Drain Pipe		mm OD 25						

Technical Specifications - 2-Way Cassette

Model		MTC-022CS	MTC-028CS	MTC-036CS	MTC-045CS	MTC-056CS	MTC-071CS
Indoor Unit Power Supply		220-240V / 1PH / 50Hz					
Nominal Cooling Capacity		kW 2.20	2.80	3.60	4.50	5.60	7.10
Nominal Heating Capacity		kW 2.60	3.20	4.00	5.00	6.30	8.00
Airflow Range (H / L)		l/s 182 / 114	182 / 114	201 / 127	236 / 153	272 / 186	333 / 214
Dimensions (H x W x D)		Indoor mm 299 x 1259 x 591					
		Panel mm 53 x 1430 x 680					
Weight		Indoor kg 29.7	29.7	29.7	31.6	31.6	31.6
		Panel kg 11	11	11	11	11	11
Sound Pressure Level		H / L dBA 33 / 27	33 / 24	35 / 25	37 / 30	39 / 30	44 / 34
Refrigerant Piping		Liquid Line mm 6.35	6.35	6.35	6.35	6.35	9.52
		Gas Line mm 12.7	12.7	12.7	12.7	12.7	15.9
Drain Pipe		mm OD 32					



Find out more
actronair.com.au/minivrf

Technical Specifications - 4-Way Compact Cassette

Model		MCC-015CS	MCC-022CS	MCC-028CS	MCC-036CS	MCC-045CS	MCC-056CS	MCC-063CS
Indoor Unit Power Supply		220-230V / 1PH / 50Hz						
Nominal Cooling Capacity		kW 1.50	2.20	2.80	3.60	4.50	5.60	6.30
Nominal Heating Capacity		kW 1.80	2.40	3.20	4.00	5.00	6.30	7.10
Airflow Range (H / L)		l/s 125 / 82	125 / 82	142 / 94	147 / 96	178 / 118	225 / 149	251 / 168
Dimensions (H x W x D)		Indoor mm 235 x 575 x 638						
		Panel mm 65 x 620 x 620						
Weight		Indoor kg 13	13	13	14	15	15	15
		Panel kg 2.3	2.3	2.3	2.3	2.3	2.3	2.3
Sound Pressure Level		H / L dBA 29 / 25	29 / 25	30 / 25	31 / 25.5	36.5 / 26.5	39 / 32	43 / 33.5
Sound Power Level		H / L dBA 40 / 38	40 / 38	42 / 38	42 / 38	44 / 41	48 / 41	51 / 42
Refrigerant Piping		Liquid Line mm 6.35	6.35	6.35	6.35	6.35	6.35	9.52
		Gas Line mm 12.7	12.7	12.7	12.7	12.7	12.7	15.9
Drain Pipe		mm OD 25						

Technical Specifications - 4-Way Cassette

Model		MFC-028CS	MFC-036CS	MFC-045CS	MFC-056CS	MFC-071CS
Indoor Unit Power Supply		220-230V / 1PH / 50Hz				
Nominal Cooling Capacity		kW 2.80	3.60	4.50	5.60	7.10
Nominal Heating Capacity		kW 3.20	4.00	5.00	6.30	8.00
Airflow Range (H / L)		l/s 219 / 137	219 / 137	253 / 136	233 / 151	278 / 183
Dimensions (H x W x D)		Indoor mm 204 x 840 x 840				
		Panel mm 53 x 950 x 950				
Weight		Indoor kg 18	18	18	19.5	19.5
		Panel kg 5.6	5.6	5.6	5.6	5.8
Sound Pressure Level		H / L dBA 30 / 25	30 / 25	37 / 27	33 / 27	37 / 28
Sound Power Level		H / L dBA 44 / 39	44 / 39	52 / 40	49 / 44	52 / 44
Refrigerant Piping		Liquid Line mm 6.35	6.35	6.35	6.35	9.52
		Gas Line mm 12.7	12.7	12.7	12.7	15.9
Drain Pipe		mm OD 25				

Technical Specifications - 4-Way Cassette

Model		MFC-080CS	MFC-090CS	MFC-100CS	MFC-112CS	MFC-140CS
Indoor Unit Power Supply		220-230V / 1PH / 50Hz				
Nominal Cooling Capacity		kW 8.00	9.00	10.00	11.20	14.00
Nominal Heating Capacity		kW 9.00	10.00	11.20	12.50	16.00
Airflow Range (H / L)		l/s 306 / 171	369 / 218	408 / 225	444 / 272	528 / 339
Dimensions (H x W x D)		Indoor mm 204 x 840 x 840				
		Panel mm 53 x 950 x 950				
Weight		Indoor kg 19.5	21.5	21.5	21.5	21.5
		Panel kg 5.8	5.8	5.8	5.8	5.8
Sound Pressure Level		H / L dBA 42.5 / 30	38 / 29	43 / 33	41 / 33	47.5 / 36.5
Sound Power Level		H / L dBA 57 / 45	55 / 47	58 / 47	57 / 51	64 / 54
Refrigerant Piping		Liquid Line mm 9.52	9.52	9.52	9.52	9.52
		Gas Line mm 15.9	15.9	15.9	15.9	15.9
Drain Pipe		mm OD 25				

Foot Notes:

- Indoor temperature 27°C DB, 19°C WB; outdoor temperature 35°C DB; equivalent refrigerant piping length 7.5m with zero level difference.
- Indoor temperature 20°C DB; outdoor temperature 7°C DB; equivalent refrigerant piping length 7.5m with zero level difference.
- Fan motor speed and airflow rate are from the highest speed to the lowest speed, there are a total of 7 speeds for each model, please refer to the Technical Catalogue for full airflow rates.
- Stable operation external static pressure range. (Note: setting external static pressure outside the unit's optimal static pressure range may lead to higher noise levels and lower airflow rate. For optimal external static pressure range, please refer to the unit's installation manual.)
- Unit body dimensions given are the largest external dimensions of the unit.
- Sound pressure level is from highest level to lowest level, there are a total of 7 sound levels for each model, please refer to the Technical Catalogue for full sound levels. Sound pressure level is measured in an anechoic chamber.

Important Notes:

- The Local Electricity Supply Authority may require limits on - starting current, running current and voltage drop, please check prior to purchase.
- When the outdoor temperature exceeds the rated conditions, the cooling/heating capacities may decrease the rated net values.
- Specifications subject to change without notice.
- All pictures shown are for illustration purposes only.

Warranty:

For full terms and conditions of ActronAir warranty, please refer to warranty terms document - www.actronair.com.au

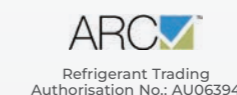

Technical Specifications - Slim Duct

Model		MSD-015CS	MSD-022CS	MSD-028CS	MSD-036CS	MSD-045CS
Indoor Unit Power Supply		220-230V / 1PH / 50Hz				
Nominal Cooling Capacity	kW	1.50	2.20	2.80	3.60	4.50
Nominal Heating Capacity	kW	1.80	2.50	3.20	4.00	5.00
Airflow Range (H / L)	l/s	94 / 81	103 / 82	128 / 83	168 / 89	222 / 121
External Static Pressure	Pa	10 (10-50)				
Dimensions (H x W x D)	mm	199 x 653 x 470	199 x 653 x 470	199 x 653 x 470	199 x 803 x 470	199 x 1003 x 470
Weight	kg	11.5	11.5	11.5	13	16.5
Sound Pressure Level	H / L dBA	27 / 22	28 / 22	30 / 22	30 / 22	33 / 26
Sound Power Level	H / L dBA	43.5 / 40	46 / 40	50.5 / 40	50.5 / 43	52 / 43
Refrigerant Piping	Liquid Line	mm	6.35	6.35	6.35	6.35
	Gas Line	mm	12.7	12.7	12.7	12.7
Drain Pipe	mm	OD 32				

Technical Specifications - Slim Duct

Model		MSD-056CS	MSD-071CS	MSD-080CS	MSD-090CS	MSD-112CS
Indoor Unit Power Supply		220-230V / 1PH / 50Hz				
Nominal Cooling Capacity	kW	5.60	7.10	8.00	9.00	11.20
Nominal Heating Capacity	kW	6.30	8.00	9.00	10.00	12.50
Airflow Range (H / L)	l/s	250 / 131	318 / 161	389 / 267	389 / 267	450 / 300
External Static Pressure	Pa	10 (10-50)	10 (10-50)	20 (10-80)		
Dimensions (H x W x D)	mm	199 x 1003 x 470	199 x 1203 x 470	199 x 1703 x 470	199 x 1703 x 470	199 x 1703 x 470
Weight	kg	16.5	20	28	28	28
Sound Pressure Level	H / L dBA	36 / 27	37 / 29	36.5 / 30.5	36.5 / 30.5	39.5 / 31.5
Sound Power Level	H / L dBA	56 / 44	57 / 47	57 / 49.5	57 / 49.5	60.5 / 50.5
Refrigerant Piping	Liquid Line	mm	6.35	9.52	9.52	9.52
	Gas Line	mm	12.7	15.9	15.9	15.9
Drain Pipe	mm	OD 32				

Technical Specifications - MSP Duct

Model		MMD-015CS	MMD-022CS	MMD-028CS	MMD-036CS	MMD-045CS	MMD-056CS
Indoor Unit Power Supply		220-230V / 1PH / 50Hz					
Nominal Cooling Capacity	kW	1.50	2.20	2.80	3.60	4.50	5.60
Nominal Heating Capacity	kW	1.80	2.50	3.20	4.00	5.00	6.30
Airflow Range (H / L)	l/s	131 / 78	139 / 83	150 / 89	160 / 93	185 / 114	269 / 160
External Static Pressure	Pa	30 (10-160)					
Dimensions (H x W x D)	mm	245 x 710 x 770	245 x 710 x 770	245 x 710 x 770	245 x 710 x 770	245 x 710 x 770	245 x 910 x 770
Weight	kg	18.5	18.5	18.5	18.5	19.5	24
Sound Pressure Level	H / L dBA	26.5 / 22	26.5 / 22	26.5 / 22	29 / 22	33 / 24	33 / 25
Sound Power Level	H / L dBA	46 / 37	47 / 38	47 / 38	50 / 39	53 / 41	55 / 43
Refrigerant Piping	Liquid Line	mm	6.35	6.35	6.35	6.35	6.35
	Gas Line	mm	12.7	12.7	12.7	12.7	12.7
Drain Pipe	mm	OD 25					

Technical Specifications - MSP Duct

Model		MMD-071CS	MMD-080CS	MMD-090CS	MMD-112CS	MMD-140CS	MMD-160CS
Indoor Unit Power Supply		220-230V / 1PH / 50Hz					
Nominal Cooling Capacity	kW	7.10	8.00	9.00	11.20	14.00	16.00
Nominal Heating Capacity	kW	8.00	9.00	10.00	12.50	16.00	18.00
Airflow Range (H / L)	l/s	319 / 183	376 / 224	394 / 232	542 / 319	585 / 361	653 / 389
External Static Pressure	Pa	30 (10-160)	30 (10-160)	40 (10-160)	40 (10-160)	50 (10-160)	50 (10-160)
Dimensions (H x W x D)	mm	245 x 910 x 770	245 x 1160 x 770	245 x 1160 x 770	245 x 1510 x 770	245 x 1510 x 770	245 x 1510 x 770
Weight	kg	25	30	31	37	39	39
Sound Pressure Level	H / L dBA	35 / 26	37 / 28	37 / 28	39 / 28	40 / 29	42 / 31
Sound Power Level	H / L dBA	58 / 45	59 / 47	59 / 46	60 / 50	64 / 53	65 / 52
Refrigerant Piping	Liquid Line	mm	9.52	9.52	9.52	9.52	9.52
	Gas Line	mm	15.9	15.9	15.9	15.9	15.9
Drain Pipe	mm	OD 25					

Technical Specifications - HSP Duct

Model		MHD-056CS	MHD-071CS	MHD-080CS	MHD-090CS
Indoor Unit Power Supply		220-230V / 1PH / 50Hz			
Nominal Cooling Capacity	kW	5.60	7.10	8.00	9.00
Nominal Heating Capacity	kW	6.30	8.00	9.00	10.00
Airflow Range (H / L)	l/s	TBC	TBC	TBC	TBC
External Static Pressure	Pa	80 (0-250)			
Dimensions (H x W x D)	mm	299 x 1050 x 750			
Weight	kg	35	35	35	35
Sound Pressure Level	H / L dBA	39 / 30	39 / 30	39 / 30	40 / 31
Sound Power Level	H / L dBA	59 / 47	59 / 47	59 / 47	63 / 50
Refrigerant Piping	Liquid Line	mm	6.35	9.52	9.52
	Gas Line	mm	12.7	15.9	15.9
Drain Pipe	mm	OD 25			

Technical Specifications - HSP Duct

Model		MHD-112CS	MHD-125CS	MHD-140CS	MHD-160CS
Indoor Unit Power Supply		220-230V / 1PH / 50Hz			
Nominal Cooling Capacity	kW	11.20	12.50	14.00	16.00
Nominal Heating Capacity	kW	12.50	14.00	16.00	18.00
Airflow Range (H / L)	l/s	TBC	TBC	TBC	TBC
External Static Pressure	Pa	80 (0-250)	100 (0-250)		
Dimensions (H x W x D)	mm	299 x 1400 x 750			
Weight	kg	44.5	46.5	46.5	46.5
Sound Pressure Level	H / L dBA	41 / 32	41 / 33	43 / 34	43 / 35
Sound Power Level	H / L dBA	63 / 52	66 / 54	67 / 55	68 / 57
Refrigerant Piping	Liquid Line	mm	9.52	9.52	9.52
	Gas Line	mm	15.9	15.9	15.9
Drain Pipe	mm	OD 25			

Technical Specifications - Floor Standing / Console

Model		MFF-022CS	MFF-028CS	MFF-036CS	MFF-045CS	MFF-056CS	MFF-071CS	MFF-080CS
Indoor Unit Power Supply		220-230V / 1PH / 50Hz						
Nominal Cooling Capacity	kW	2.20	2.80	3.60	4.50	5.60	7.10	8.00
Nominal Heating Capacity	kW	2.40	3.20	4.00	5.00	6.30	8.00	9.00
Airflow Range	H / L l/s	141 / 121	141 / 121	148 / 115	191 / 146	259 / 212	293 / 234	293 / 234
Dimensions (H x W x D)	mm	495 x 1020 x 200		495 x 1240 x 200		591 x 1360 x 200		
Weight Indoor	kg	21.1	21.1	21.9	26.3	32.1	33.3	33.3
Sound Pressure Level	H / L dBA	36 / 32	36 / 32	38 / 32	43 / 37	41.5 / 36	46 / 41	46 / 41
Refrigerant Piping	Liquid Line	mm	6.35	6.35	6.35	6.35	6.35	9.52
	Gas Line	mm	12.7	12.7	12.7	12.7	12.7	15.9
Drain Pipe	mm	OD 18.5						

Controls Options

Model	MRC-101CS	MWC-B01CS	MWC-S01CS	MWC-P01CS
	Wireless Controller	Basic Wired Controller	Standard Wired Controller	Premium Wired Controller
High Wall	Optional	Optional	Optional	Optional
1-Way Cassette	Optional	Optional	Optional	Optional
2-Way Cassette	Optional	Optional	Optional	Optional
4-Way Compact Cassette	Optional	Optional	Optional	Optional
4-Way Cassette	Optional	Optional	Optional	Optional
Slim Duct	Optional	Optional	Optional	Optional
MSP Duct	Optional	Optional	Optional	Optional
HSP Duct	Optional	Optional	Optional	Optional
Floor Standing Console	Optional	Optional	Optional	Optional

Foot Notes:

- Indoor temperature 27°C DB, 19°C WB; outdoor temperature 35°C DB; equivalent refrigerant piping length 7.5m with zero level difference.
- Indoor temperature 20°C DB; outdoor temperature 7°C DB; equivalent refrigerant piping length 7.5m with zero level difference.
- Fan motor speed and airflow rate are from the highest speed to the lowest speed, there are a total of 7 speeds for each model, please refer to the Technical Catalogue for full airflow rates.
- Stable operation external static pressure range. (Note: setting external static pressure outside the unit's optimal static pressure range may lead to higher noise levels and lower airflow rate. For optimal external static pressure range, please refer to the unit's installation manual.)
- Unit body dimensions given are the largest external dimensions of the unit.
- Sound pressure level is from highest level to lowest level, there are a total of 7 sound levels for each model, please refer to the Technical Catalogue for full sound levels. Sound pressure level is measured in an anechoic chamber.



Find out more
actronair.com.au/minivrf



CONTROLS.

Where intuitive controls meet personalised comfort.

ECOFLEX Mini allows you to control air conditioning in different living spaces with ease and precision. With its intuitive control systems, **ECOFLEX Mini** ensures that you can effortlessly adjust the temperature in any room to your desired comfort level.

INDEX

36	Local Controls
38	Central Control
39	Gateways

Wireless Controller MRC-I01CS

Specifications

Dimensions (H x W x D): 170mm x 47mm x 25mm



Functions

	Run/Stop
	Operation Mode
	Temperature Setting
	Auto Mode Setting
	Temperature Setting 0.5°C/1.0°C
Setting	Night Silent Mode Setting
	Fan Speed Setting 3 & 7 speed
	Horizontal / Vertical Louver Control
	On/Off Timer
	Self Clean Mode Setting
Service	Indoor Unit Address Setting
	Indoor Unit Parameter Setting
	Indoor Unit Spot Check Function

Standard Wired Controller MWC-S01CS

Specifications

Dimensions (H x W x D): 86mm x 86mm x 20mm



Functions

	Run/Stop
	Operation Mode
	Temperature Setting
	Auto Mode Setting
	Temperature Setting 0.5°C/1.0°C
Setting	Night Silent Mode Setting
	Filter Notification
	Sound Off Function
	Group Control for up to 16 Indoors
	2 Controller connectivity
	After Hours Operation
	Weekly Scheduling
	Fan Speed Setting 3 & 7 speed
	Horizontal / Vertical Louver Control
	Self Clean Mode Setting
Service	Indoor Unit Address Setting
	Indoor Unit Parameter Setting
	Indoor Unit Spot Check Function

Basic Wired Controller MWC-B01CS

Specifications

Dimensions (H x W x D): 86mm x 86mm x 20mm



Functions

	Run/Stop
	Operation Mode
	Temperature Setting
	Auto Mode Setting
	Temperature Setting 0.5°C/1.0°C
Setting	Night Silent Mode Setting
	Filter Notification
	Sound Off Function
	Group Control for up to 16 Indoors
	2 Controller connectivity
	Fan Speed Setting 3 & 7 speed
	Horizontal / Vertical Louver Control
	On/Off Timer
	Self Clean Mode Setting
Service	Indoor Unit Address Setting
	Indoor Unit Parameter Setting
	Indoor Unit Spot Check Function

Premium Wired Controller MWC-P01CS

Specifications

Dimensions (H x W x D): 120mm x 120mm x 18mm



Functions

	Run/Stop
	Operation Mode
	Temperature Setting
	Auto Mode Setting
	Temperature Setting 0.5°C/1.0°C
Setting	Night Silent Mode Setting
	Filter Notification
	Sound Off Function
	Group Control for up to 16 Indoors
	2 Controller connectivity
	After Hours Operation
	Weekly Scheduling
	Fan Speed Setting 3 & 7 speed
	Horizontal / Vertical Louver Control
	Self Clean Mode Setting
Service	Indoor Unit Address Setting
	Indoor Unit Parameter Setting
	Indoor Unit Spot Check Function

Central Controller MCC-T01CS

Specifications

Dimensions (H x W x D): 187mm x 287mm x 32mm



Functions

Setting	10.1 Inch Touch Screen	Connections	LAN Cable Support
	Up to 384 Indoor unit connectivity or 48 systems		USB Support
	Run/Stop		Web Access
	Operation Mode		
	Temperature Setting		
	Auto Mode Setting		
	Device Monitor & Control		
	Night Silent Mode Setting		
	Auto Energy Saving Setting		
	Priority Mode Setting		
	Scheduling Templates		
	Self Clean Mode Setting		
	Scheduling Functions		
	Group Management Functions		
	2-Level Permissions		
Operation Log			
Service	Indoor Unit Address Setting		
	Indoor Unit Parameter Setting		
	Indoor Unit Spot Check Function		

BACNET Gateway MGW-BACCS

Specifications

Dimensions (H x W x D): 124mm x 154mm x 51.5mm



Functions

Setting	3 x XYE Ports – each port can connect a maximum of 8 systems / 64 IDUs and 24 ODUs
	Unit monitoring: Room temperature, error code, outlet air temperature, EXV opening, alarm indication, Fan Speed, Temperature Setting, Remote controller lock, Fan Lock, Dual Set points, Temperature Limits, and Swing settings.
	Indoor Unit Control: On/Off, Mode, Fan Speed, Temperature, Remote controller lock, Temperature limits
	Outdoor Unit Monitor: Mode Status, On/Off, Alarm, Compressor frequency, Ambient Temperature, Discharge temperature

MODBUS Gateway MGW-MODCS

Specifications

Dimensions (H x W x D): 124mm x 154mm x 51.5mm



Functions

Setting	Maximum of 64 indoor units can be controlled.
	Maximum of 8 refrigerant systems can be controlled
	Modbus RTU or Modbus TCP/IP Protocol support is available.
	Indoor Unit Monitor: Error Code, Model, Indoor Temperature, On/Off, Mode, Fan Speed, Temperature, Mode Lock, Fan Speed Lock, Remote controller lock, Wired controller lock, Temperature limits, Swing Lock etc.
	Outdoor Unit Monitor: Operating indoor units, Error code.



ActronAir

Australian family owned
and operated since 1984

actronair.com.au
1300 522 722

© iPhone, iPod and iPad are registered trademarks of Apple Inc. © Android is a trademark of Google Inc.

ActronAir maintains an unwavering dedication to incessantly enhancing its product offerings in order to uphold the utmost standards of quality and reliability, while simultaneously adhering to local regulations and market demands. The specifications outlined within this document are subject to modification without prior notice, as ActronAir strives to integrate the most recent advancements and innovations into its product line-up for the benefit of its valued customers. It is important to note that the information provided in this brochure is purely informative in nature and should not be utilised as a substitute for the Engineering or Installation Manuals. The cooling and heating capacities referenced for the products represent nominal capacities under standard operating conditions. ActronAir, the brand, hereby absolves itself of any responsibility in the broadcast sense, for any form of damage, whether direct or indirect, that may arise from the utilisation and interpretation of the recommendations provided within this document.