

VCC



VARIABLE CAPACITY COMMERCIAL SERIES (72kW - 96kW)



actronair.com.au

ACTRONAIR. Australia needs Australian air conditioning.

Australian-Owned & Operated

ActronAir has been proudly providing commercial air conditioning systems that exemplify Australian ingenuity and craftsmanship since 1984. These systems are intricately designed and skillfully manufactured in Australia, uniquely customized to adeptly manage the wide range of climate conditions found within the country.

Trusted by Thousands

At ActronAir, we have built a strong and enduring reputation through years of dedication and excellence, earning the trust of countless customers across Australia. Our commitment to quality, reliability, and performance has made us the preferred choice in the country.

Innovation at its core

Innovation is central to ActronAir's identity, as we continuously invest in research and development to maintain a leading-edge position in technology, driving advancements in our air conditioning solutions.

Tailored Solutions

We acknowledge the individuality of each commercial space and offer a wide range of customised air conditioning solutions to cater to various specific needs and preferences. We emphasise the importance of providing tailored solutions to meet the unique requirements of different environments.

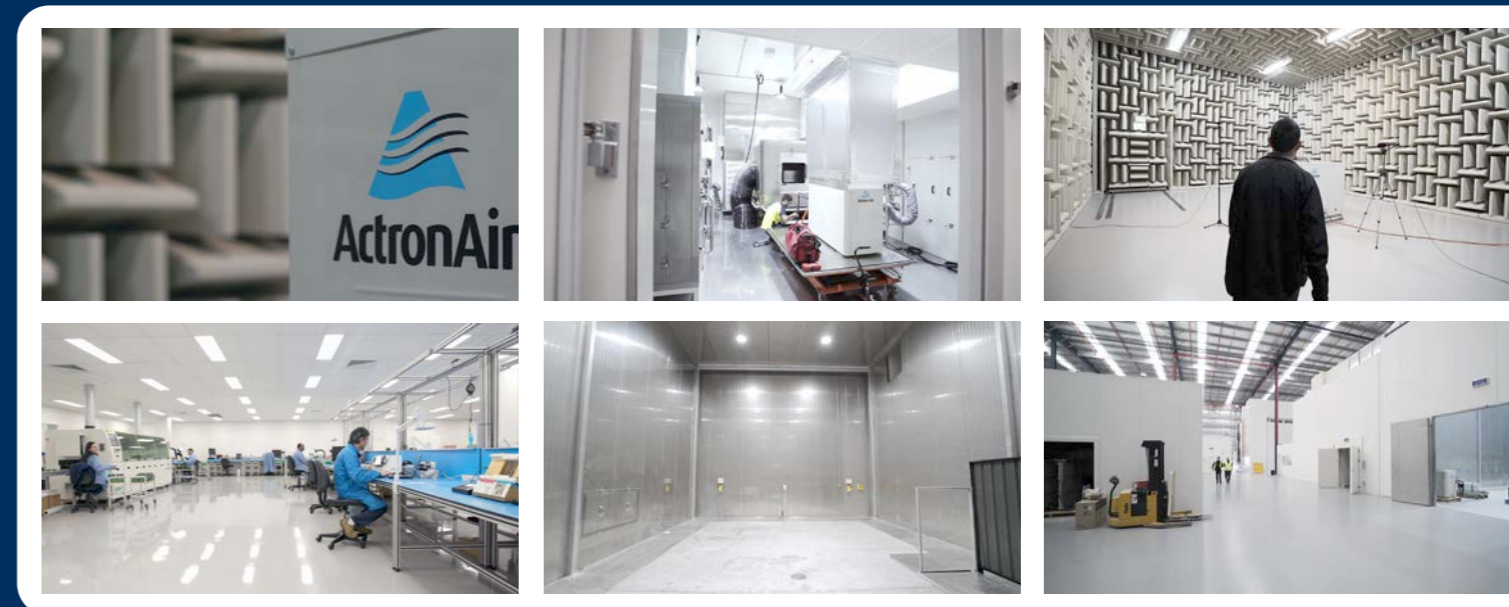



FEATURES.

Powering Efficiency, Innovating Comfort: Unleashing the future of Heating & Cooling with Variable Capacity Commercial [VCC] Series.

Designed to deliver exceptional performance while ensuring energy efficiency, our Variable Capacity Commercial series is the ideal solution for retail and commercial applications.

Inverter Compressors

Inverter compressor technology represents advancements in the field of HVAC systems. Providing dynamic management of indoor air temperatures, delivering a superior level of year-round comfort while concurrently setting new benchmarks in energy efficiency within the industry.

Condenser EC Fans

The high static EC fans excel not only in efficiency but also in providing a quieter performance. They are engineered to deliver a rated outdoor airflow of up to 90Pa, offering the added convenience of selectable 10Pa increments.

EC Plug Fans

EC plug high static fans showcase outstanding efficiency thanks to their advanced motor technology. They enable precise variable speed control, systematically adjusting airflow and optimising energy usage to match specific demands, making them suitable for applications with pressure requirements of up to 500Pa.



Coated Coil Protection

ActronAir employs Hydrophilic Blue Fin Coil Coat Protection for both the indoor and outdoor coils featured in the VCC product range. This specialised coating serves a dual purpose: mitigating corrosion resulting from the challenging Australian environmental conditions and enhancing the defrosting mechanism, thereby augmenting the overall heating efficiency.

Low Ambient Cooling

Our system excels at delivering efficient cooling, even when faced with outdoor temperatures as low as +5 degrees. This feature proves invaluable in regions where the weather can be quite cool, and the need for cooling persists despite low outdoor temperatures such as applications with a high internal load all year round.

Wide Operating Range

The Variable Capacity Commercial range promises exceptional durability and comfort, capable of withstanding extreme environmental conditions, from **-10°C up to 57°C**. They feature advanced technology for efficient and reliable performance, ensuring comfort and productivity in any weather.



FEATURES.

Enhance your commercial space with Actron's Variable Capacity Commercial Split Ducted & Packaged Range, now extending to 96kW.

Engineered for versatility and energy efficiency, our solutions cater to a diverse range of commercial applications.

Powerful Performance with Tru-Max

The Variable Capacity Commercial (VCC) units provide a wide range of heating and cooling capacities, ensuring reliable and precise temperature control even during peak demand. These system optimise energy efficiency and can exceed the rated capacity by up to 10% all whilst maintaining utmost comfort and ensuring the system's efficiency even at Tru-Max capacities.

EVA960T / CRV960T Capacity Range

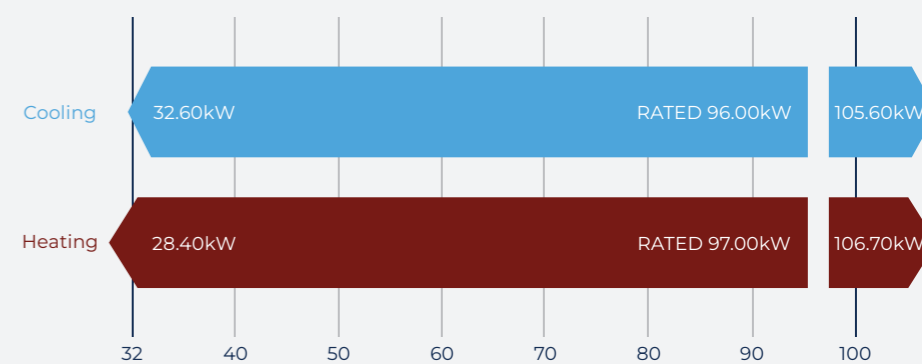

Smart Fan Control Technology

While the compressor is off, maintaining airflow is still essential for indoor air quality and circulation. The compressor off fan operation ensures that the fans run at an appropriate, energy efficient speed to achieve this without overusing power. By reducing the indoor fan speed by 50%, it can result in a reduction in supply fan power consumption in **excess of 70%**

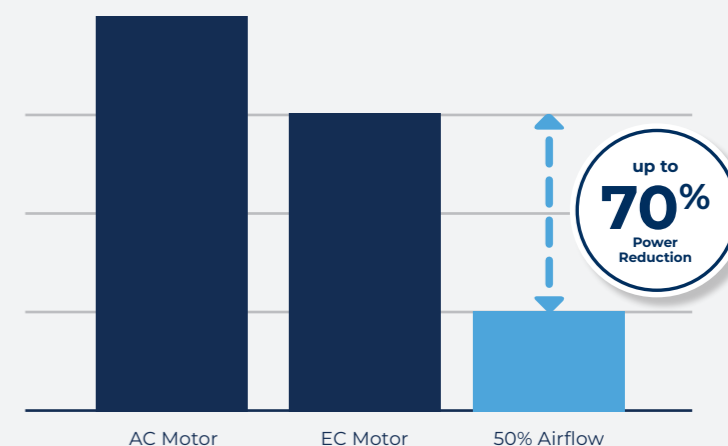

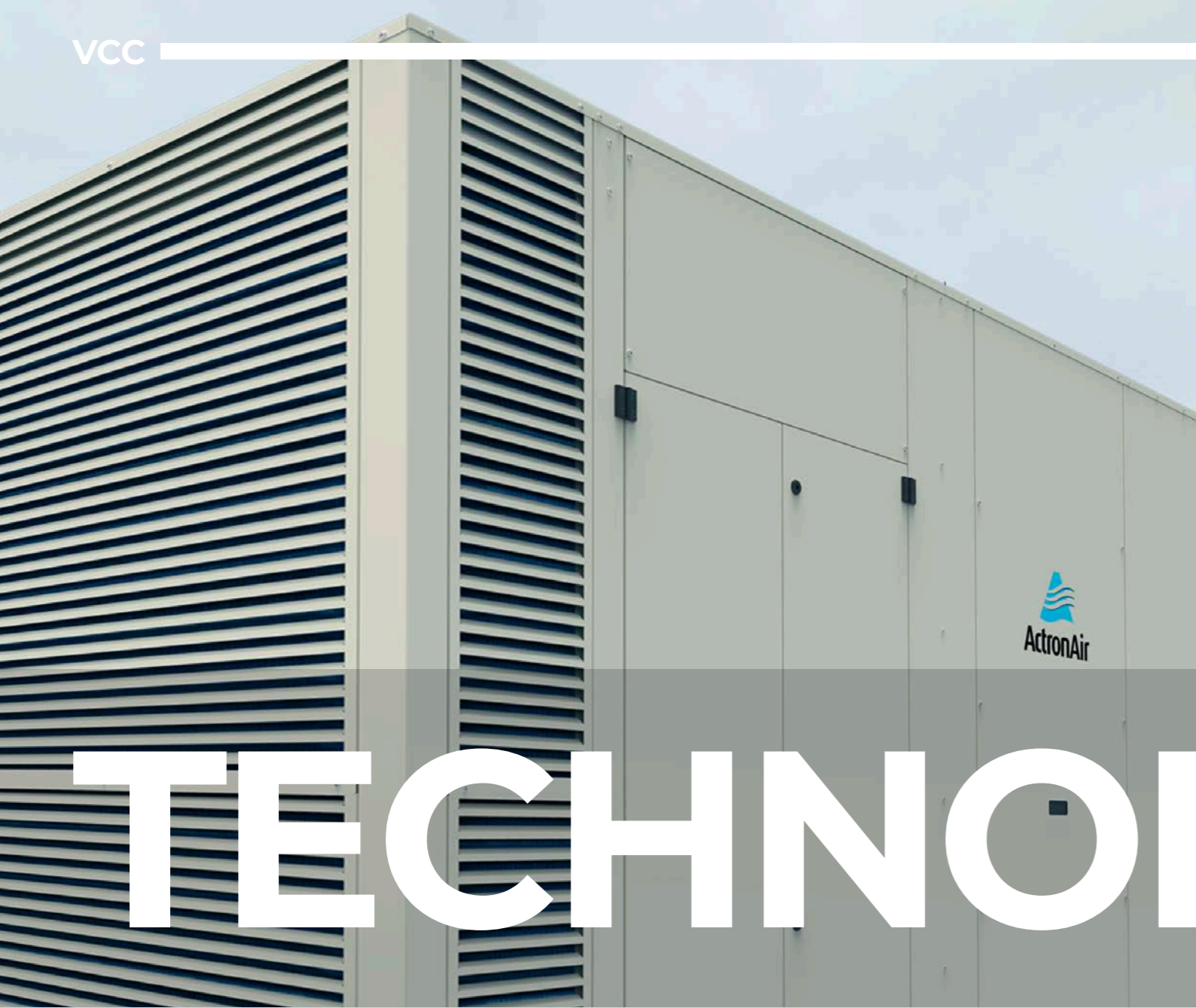

TECHNOLOGY.

ActronAir's Tru-Inverter technology is seamlessly integrated into the Variable Capacity Commercial series, enhancing temperature control.

Our inverter compressor technology offers precise control of indoor air temperatures, ensuring superior comfort while leading the way in energy efficiency.

Inverter Compressors

The Variable Capacity Commercial series incorporates innovative inverter compressors that adapt to the specific operating conditions, bringing forth several advantages such as:

- * **Energy Efficiency:** Actron's inverter compressors minimise the energy required, optimising the system's energy efficiency and ultimately maximising performance with optimised efficiency.
- * **Consistent Comfort:** The precise control of the inverter compressor ensures a consistent and comfortable indoor environment, reducing temperature fluctuations.
- * **Cost Savings:** By reducing energy consumption, this technology results in substantial cost savings, making it an economically viable choice for businesses seeking efficiency.

Tru-Inverter Technology

Fixed-speed air conditioners operate as single-speed on/off systems, cycling on and off when the temperatures deviates from the set level. This results in inefficient energy consumption and inconsistent room temperature maintenance. In contrast, ActronAir's True-Inverter Technology paired with variable capacity inverter compressors offer precise load adjustment, enhancing temperature control.

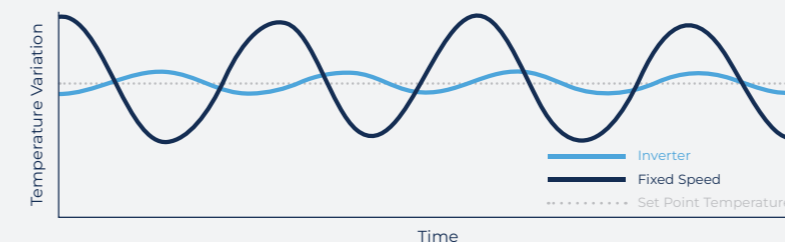



EFFICIENCY.

Superior performance with Actron's Variable Capacity Commercial range, featuring high static EC plug fans at its core-innovation and efficiency for an unmatched commercial environment.

EC Plug fans deliver up to **500Pa**, with substantial energy savings. Surpassing both belt-driven fans and AC fans in performance, they offer unparalleled energy efficiency. Compared to belt-driven fans, they achieve a remarkable efficiency increase of up to **50%**, and compared to AC fans, they achieve a **20%** in efficiency gain.

Part Load Efficiency

The Variable Capacity Commercial series can deliver substantial power consumption savings, up to 30%, when operating at partial load. Part load efficiency characterises the effectiveness of air conditioning units when they run below their full capacity. This situation is common for commercial units designed for peak demand but often operating at reduced loads during off-peak periods.

* We have referenced 3 climate zones, Hot, Average & Cold along with bin hour operation in each of the climate zones, providing us data on two variables - different climates and part load vs full load

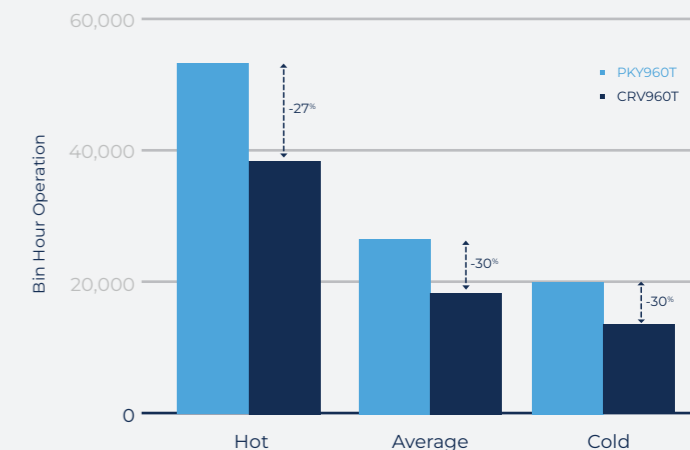

Seasonal Energy Efficiency [SEER]

Australian standards AS3823.1.1 and AS3823.2 define test conditions for rating products for cold, average and hot climates. The standard is based on testing at several temperatures at both full and part loads and extrapolating this into a curve of performance that covers all temperature points, rather than the past method that tests the energy efficiency at full load and at two or three temperatures.

Testing conducted under this SEER standard shows the difference in energy efficiency depending on the climate zone in which it is used.

The higher SEER values of the new larger Variable Capacity Commercial units signifies their enhanced ability to deliver greater cooling output while utilising less energy, resulting in improved overall energy efficiency and reduced energy consumption.

Variable Capacity Commercial vs Tri-Capacity

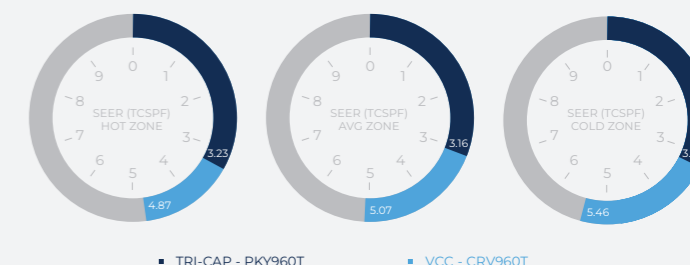



FLEXIBILITY.

Discover a world of flexibility with ActronAir's Variable Capacity Commercial Series.

From customisable handing configurations in our packaged units to the vertical indoor configurations in the ducted split range, you have the flexibility to design your HVAC solution to suit almost any commercial application.

Handing Options

The Variable Capacity Commercial Package systems 72~96kW range, introduce a remarkable level of flexibility, providing an extensive array of up to 32 different handing configurations at time of order. This versatile feature allows you to tailor the system to meet the specific requirements of a wide range of applications.

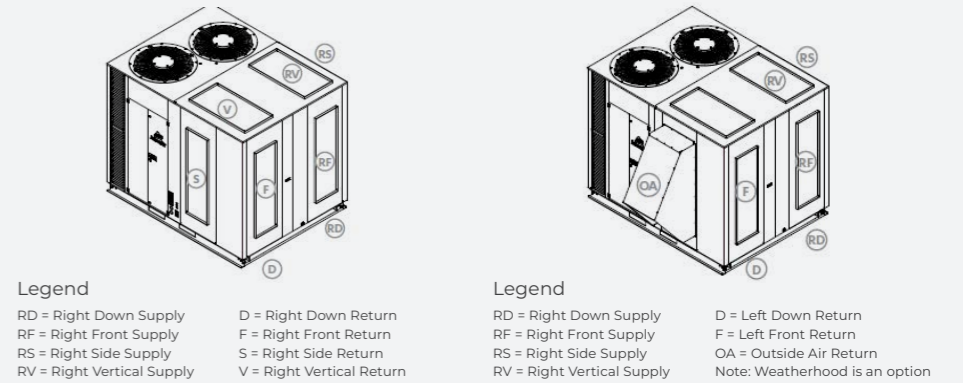

Split Duct Vertical Discharge Indoor

The Variable Capacity Commercial Split Ducted indoor units have been thoughtfully designed to cater to the diverse demands of different sites. To enhance their adaptability, we offer the option of vertical discharge, allowing you to tailor the units precisely to your site's unique requirements.

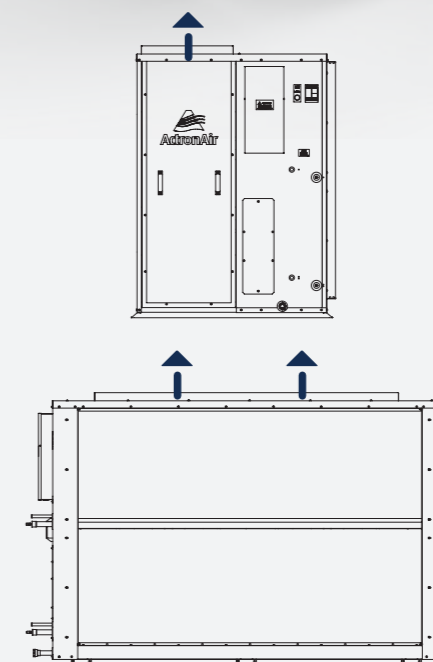

Interchangeable Panels On-site

Site configurable interchangeable front and side panels allows for greater site flexibility at the time of installation minimising the risk of installation downtime.



PACKAGE.

Experience the power of choice with Actron's Variable Capacity Commercial Package units now expanding to 96kW.

We're redefining flexibility in HVAC solutions, offering a wider selection to meet various requirements and providing an even greater range of options for your comfort and efficiency needs.

Insulated Performance

Includes 25mm foil-faced insulation as a standard inclusion, reinforced with welded pins for increased durability. The insulation aid with improving efficiency by reducing heat gain or loss and also offers a healthier choice due to its resistance to mold and mildew.

Double-Sloped Main Drain Tray

The main drain tray has been cleverly engineered with a double-slope design, enhancing the unit's drainage capabilities.



Louvered Grille Guard

Embracing a unique powder-coated louvered grille guard, this product assures protection against challenging conditions encountered in Australia. From hailstorms to the relentless solar impact of the sun, this design is specifically crafted to shield against the natural elements.

Pull out Filter Tray

Pull-out filter tray, maintenance made effortless with its hasslefree removal that requires no screws. Simply pull out the tray, and maintenance becomes a breeze.



* Filters not included / filter thickness: 100mm

CONTROLS.

Intuitive Interface

Take command of your commercial system effortlessly. Whether it's temperature adjustments or fine-tuning the 7-day time clock, the NEO's 7" backlit screen presents a userfriendly, intuitive interface that's at your fingertips.

Precise Comfort Control

When it comes to ensuring comfort in commercial spaces, Actron has your back. With NEO, you can precisely set your temperature in 0.5°C increments, allowing you to select the perfect comfort level for your needs, ensuring productivity remains uninterrupted.

Temperature/Humidity Sensor

On-board temperature and humidity sensors mean the NEO Touch Controller displays precise indoor room temperature and humidity levels.

Physical Dimensions:
118mm x 212mm x 17mm (H x W x D)

** Complies with NCC 2022 for after hours operations



Award winning controls for award winning comfort.

NEO is ActronAir's latest entry in a line of award-winning control products. Building on the unique design and superior performance that ActronAir controls are known for, NEO brings the best in premium control technology to more people than ever before.



Wireless Convenience

NEO Sense remote temperature sensors, available in Ceramic White and Jet Black, are not hindered by cables thanks to long-range Bluetooth technology and their ability to be powered by a battery. Enjoy the freedom to install the sensor where you need it most.

Physical Dimensions:
80mm x 83mm x 19mm (H x W x D)



CONTROLS.

Controls solutions for almost any commercial application.

ActronAir offers a range of controllers to cater to commercial requirements, from our award winning **NEO** through to the Group Controller and Modbus BMS where you have the flexibility of remote site monitoring.

Controller Configuration	Home
Sensor Setup	Enable Outside Air Humidity Sensor <input checked="" type="checkbox"/>
Fan Configuration	Maximum Humidity 60 %
Draft Reduction	Control Moisture Content <input checked="" type="checkbox"/>
Service Timers	Maximum Moisture Content (g/kg) 8
Control Parameters	Maximum Enthalpy (kJ/kg) 10
	Set Enthalpy Difference (Δh kJ/kg) 10
Advanced Options	Mechanical Cooling offset coefficient 1.5

Physical Dimensions:

118mm x 212mm x 17mm (H x W x D)

** Complies with NCC 2022 for after hours operations



LC7-2



The LC7-2 boasts a sleek and sophisticated design, complemented by a user-friendly interface that allows for effortless navigation.

- 7 Day Programmable
- 24hr ON/OFF Timer
- Auto, Heat & Cool Modes
- Filter change light indicator

Group Control



Designed with simplicity in mind, the Group control enables easy utilisation of advanced scheduling functions.

- * Expansion module may be required
- Control up to 15 units
- 7 Day & Multi Event Scheduling
- Web Interface
- Organise units in up to 4 groups

3rd Party Controls



Simple terminals for compressor control on/off and modulation, fan speed and operating modes.

Modbus BMS



Basic & Advanced BMS Control

- Modbus 485
- Fan Speed & Mode
- Operation Mode



COMMISSIONING.

Unlock the future of HVAC commissioning with Actron Link, your ultimate tool for seamless configuration in the Variable Capacity Commercial series.

From setting up economy cycle to configuring desuperheaters, Actron Link provides contractors with quick and easy commissioning, all in the palm of their hand.

Commissioning with Actron Link

After the successful installation of the Variable Capacity Commercial unit on-site, simplicity and efficiency remain paramount in the commissioning process. That's why Actron introduced Actron Link, an intuitive commissioning tool.

Actron Link harnesses the power of Bluetooth technology, allowing seamless pairing with the system. This innovative approach streamlines the configuration and commissioning process, ensuring that the system is up and running swiftly and smoothly, saving valuable time and resources while promoting hassle-free operation.

Bluetooth Commissioning Tool (BCT) Hardware

The BCT is a standard inclusion in our larger 72-96kW Variable Capacity Commercial units. Recognizing that larger units often involve additional configuration demands based on site-specific requirements, we aim to provide enhanced convenience and efficiency with this inclusive tool.

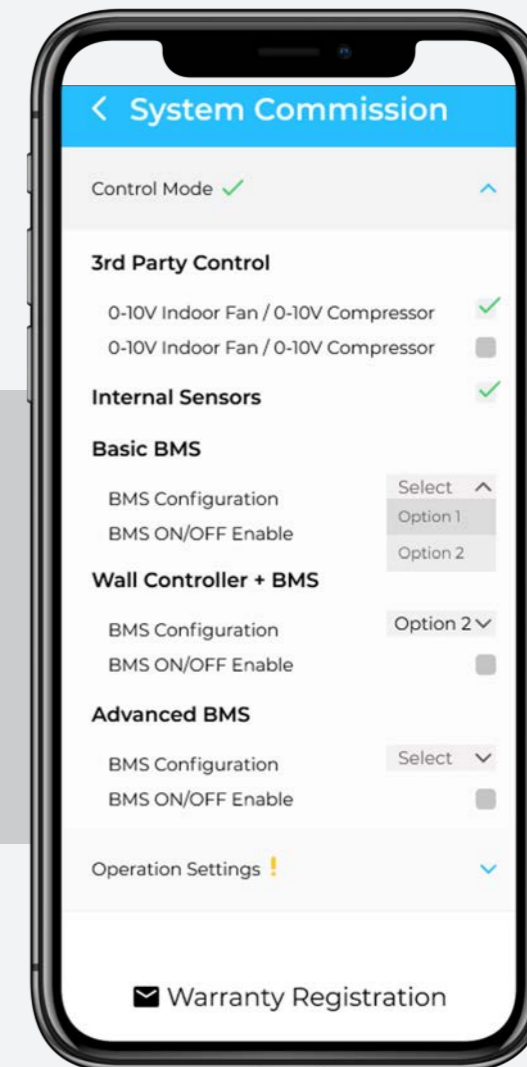

Monitoring with Actron Link

At Actron, we understand that simplifying contractors' lives is an ongoing commitment that extends beyond the commissioning stage. That's why we go the extra mile by providing valuable tools like dashboards accessible through Actron Link. These dashboards serve as a valuable resource for service and fault finding, offering real-time insights and diagnostics to ensure the seamless operation and maintenance of your system. Our commitment to supporting contractors throughout the system's lifecycle underscores our dedication to making their work easier and more efficient.

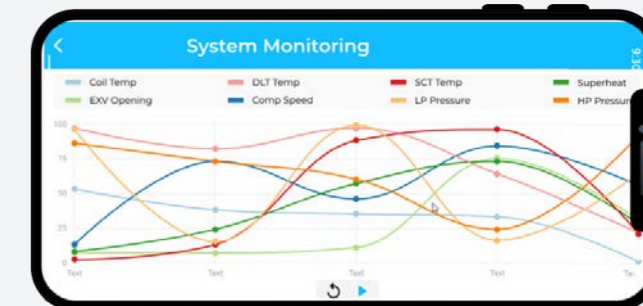



OPTIONALS.

Tailor your HVAC solution to perfection with Actron's optional extras for the Variable Capacity Commercial systems.

From capturing waste heat and transferring it into a valuable resource to elevating your indoor environment, we offer the keys to customizing efficiency and comfort to meet your site's unique needs.

Hot Water Heat Reclaim (Desuperheater) *

This technology efficiently recycles excess heat that would typically go to waste and transforms it into a valuable resource.

The desuperheater allows for rapid heating of 500 liters of water from 25 degrees to 55 degrees within just 129 minutes. With an impressive average capacity of 8.11kW/hr, this not only enhances energy efficiency as a secondary system to heat water but also exemplifies our dedication to delivering sustainable, eco-friendly solutions that cater to both your heating and environmental needs.

* Desuperheater is available as an option.

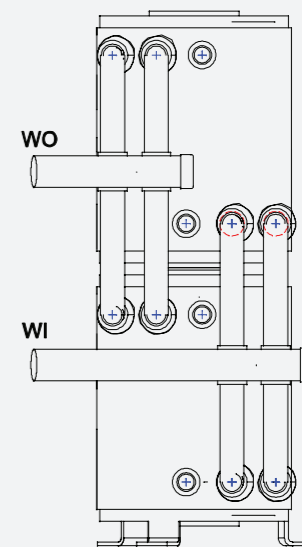

Economiser Cycle Option

The Economy Cycle stands as a cornerstone of our commitment to substantial energy savings. This intelligent feature comes into play when the ambient air outside falls below the set point required for cooling. In such circumstances, the compressor is strategically cycled off, and the outside air dampers open. Meanwhile, the supply air fan remains operational, introducing outside air into the conditioned space. This minimises energy usage and ensures that your indoor environment remains consistently comfortable.

Economiser with Spill Air

The Variable Capacity Commercial systems 72~96kW, offer enhanced versatility through the integration of an Economiser with a spill air option. This advanced feature allows for even greater control and optimisation of your HVAC system. By drawing on the Economiser's capabilities, you can efficiently introduce fresh outdoor air when conditions permit, maximising energy efficiency and ensuring a healthy indoor environment. The spill air option offers an extra layer of flexibility, guaranteeing that your system adapts seamlessly to the specific requirements of your commercial space.

Technical Specifications

VCC Package System (72.00 - 96.00kW)

Australian made products includes NEO, outdoor and indoor unit



Technical Information							
		PACKAGE UNIT			SPLIT UNIT		
PACKAGE / OUTDOOR MODEL		PKV720T	PKV850T	PKV960T	CRV720T	CRV850T	CRV960T
INDOOR MODEL					EVA720T	EVA850T	EVA960T
Total (Gross) Capacity (kW) (AS/NZS3823.1.2)	Cooling (Rated)	73.25	86.35	98.50	73.25	86.60	98.50
	Heating (Rated)	71.25	83.80	94.50	71.25	84.30	94.30
Net (Rated) Capacity (kW) (AS/NZS3823.1.2)	Cooling (Rated)	24.00 / 71.50 / 78.65	30.00 / 84.50 / 92.95	32.60 / 96.00 / 105.60	24.20 / 72.00 / 79.20	30.30 / 85.00 / 93.50	32.60 / 96.00 / 105.60
	Heating (Rated)	23.20 / 73.00 / 80.30	25.35 / 85.50 / 94.05	31.10 / 97.00 / 106.70	23.20 / 73.00 / 80.30	25.50 / 86.00 / 94.60	28.40 / 97.00 / 106.70
Input Power (kW) (AS/NZS3823.1.2)	Cooling (Min / Rated / TruMax)	21.25	25.60	28.45	21.41	25.28	27.92
	Heating (Min / Rated / TruMax)	22.00	24.90	28.15	21.81	24.85	25.84
Input Power (kW) Tru-max	Cooling (Rated)	24.35	30.48	35.20	25.14	31.38	35.20
	Heating (Rated)	25.90	27.03	34.76	25.49	29.11	34.76
EER Rated (AS/NZS3823.1.2)	Cooling (Rated)	3.45	3.30	3.37	3.36	3.36	3.44
	Heating (Rated)	3.10	3.48	3.07	3.15	3.25	3.07
EER Tru-max	Cooling (Tru-max)	3.23	3.05	3.00	3.15	2.98	3.00
	Heating (Tru-max)	3.10	3.48	3.07	3.15	3.25	3.07
COP TRU-MAX	Cooling (Tru-max)	3.10	3.48	3.07	3.15	3.25	3.07
	Heating (Tru-max)	3.10	3.48	3.07	3.15	3.25	3.07
Seasonal Performance Factor Commercial	TCSPP (Hot / Mixed / Cold)	4.76 / 4.75 / 5.03	4.76 / 4.79 / 5.09	4.88 / 5.08 / 5.46	4.81 / 4.81 / 5.09	4.90 / 4.94 / 5.25	4.75 / 4.75 / 5.03
	HSPF (Hot / Mixed / Cold)	-	-	4.65 / 3.25 / 2.81	3.96 / 2.95 / 2.48	4.73 / 3.65 / 3.00	3.70 / 2.78 / 2.43
Power Supply - (V / Ph / Hz)	Package / Outdoor	400V / 3PH + N - / 50Hz			400V / 3PH + N - / 50Hz		
	Indoor	-			230V / 1Ph - / 50Hz and 400V / 3Ph - / 50Hz		
Rated Amps (AS/NZS3823.1.2)		33.6	39.3	42.90	33.6	39.3	42.90
Full Load Amps (AS/NZS3823.1.2) Outdoor / Indoor / Total		47.0 / 6.0 / 53.0	56.2 / 8.93 / 65.1	65.9 / 9.1 / 75.0	47.0 / 6.0 / 53.0	56.2 / 8.93 / 65.1	65.9 / 9.1 / 75.0
Circuit Breaker Amps (Suggested)		63.00	80.00	80.00	63.00	80.00	80.00
IP Rating	Outdoor	IP44			IP44		
	Indoor	IP20			IP44		
Compressor	Type / No. per Unit	Inverter Variable Speed Scroll / 2					
	Starting Method	Inbuilt Soft Starting					
No. of refrigeration Circuits / No. Capacity Stages		2 / Variable Capacity					
Refrigerant		R-410A					
Fans (Type x Number per units)	Outdoor	Variable Speed ECM / Direct Drive Axial Fan x 2					
	Indoor	Variable Speed ECM / Direct Drive Backward Curve Plug Fan x 1 (72kW), 2 (85kW & 96kW)					
Airflow Indoor (l/s)	Maximum	4500	5500	6000	4500	5500	6000
	Nominal	3800	4450	5000	3800	4450	5000
	Minimum	1000	1300	1500	1000	1300	1500
Package / Outdoor Dimensions (mm)	Depth	2710	2260	1205	1505		
	Height	1910	2400	1905	2345		
	Width	2375	2960	2280	2290		
Indoor Dimensions (mm)	Depth	-	-	-	1190		
	Height	-	-	1085	1520		
	Width	-	-	2440	2425		
Nominal Weight (kgs)	Outdoor	1096.00	1371.00	1478.00	700.00	834.00	906.00
	Indoor	-	-	-	296.00	368.00	387.00
Sound Pressure Level (dBA)	Outdoor (Quiet / Rated / Tru-Max)	63.6 / 70.2 / 70.2	63.7 / 69.0 / 69.0	63.7 / 69.0 / 69.0	63.6 / 70.2 / 70.2	63.7 / 69.0 / 69.0	63.7 / 69.0 / 69.0
Sound Power Level (dBA)	Outdoor (Quiet / Rated / Tru-Max)	80.6 / 87.2 / 87.2	80.7 / 86.0 / 86.0	80.7 / 86.0 / 86.0	80.6 / 87.2 / 87.2	80.7 / 86.0 / 86.0	80.7 / 86.0 / 86.0
MEPS Certified		Yes					

Unit Features

Feature	Option
Pre-charged with R-410A Refrigerant	Standard
Variable Speed Outdoor Fan	Standard
Reduce Indoor Fan Airflow (Compressor OFF Operation)	Standard
Removable Louvered Outdoor Coil Guard	Standard
External Stainless Screws (Outdoor/Package Only)	Standard
Hydrophilic Blue Coat Coil Fin Protection - Indoor & Outdoor	Standard
25mm Foil Faced Polyethylene Insulation - Indoor Unit	Standard
Demand Response Capability AS4755.3.2012	Standard
Low Ambient (+5°C) / High Static EC Outdoor Fan	Standard



Package Unit Find out more
actronair.com.au/commercial-packaged/vcc



Split Unit Find out more
actronair.com.au/commercial-ducted/vcc

Control Features and Options

Technical Information							
		PACKAGE UNIT			SPLIT UNIT		
OUTDOOR MODEL		PKV720T	PKV850T	PKV960T	CRV720T	CRV850T	CRV960T
INDOOR MODEL					EVA720T	EVA850T	EVA960T
ActronAir LR7-1 / LC7-2		Optional			Optional		
7 Day Programmable Time-Clock with 2 Events per Day		Standard			Standard		
24 - hour ON / OFF Timer		Standard			Standard		
Temperature Setback		Standard			Standard		
After Hours Timer (LC7-2 Only)		Standard			Standard		
Fixed, Auto, Heat, Cool, Turbo, Fan Modes and Night Mode Functions		Standard			Standard		
Fixed, Auto and Continuous Fan Operation		Standard			Standard		
2nd and 3rd Controller with Mimic Logic		Optional			Optional		
On-board Temperature Sensor		Standard			Standard		
Available in White or Grey		Optional			Optional		
ActronAir NEO		Optional			Optional		
7" Colour Touch Screen Master Controller		Standard			Standard		
In-built Wi-Fi and Bluetooth		Standard			Standard		
NEO Connect App		Standard			Standard		
On-Board Temperature, Humidity and Proximity Sensor		Standard			Standard		
Wireless Zone Sensor		Optional			Optional		
Available in White or Black		Optional			Optional		

Air Handling Configurations

T - Evaporator Top Discharge (EVA Models Only)	-	Optional
V - Evaporator Top Discharge (PKV Models Only)	Optional	-
F - Evaporator Front Discharge (PKV Models Only)	Standard	-
S - Evaporator Side Discharge (PKV Models Only)	Optional	-
D - Evaporator Down Discharge (PKV Models Only)	Optional	-
Reverse Handling	Optional	-

Variations

E - Economy Starter Kit	Optional	N/A
G - Auto Outside Air Kit	Optional	N/A
H - Manual Outside Air Kit	Optional	N/A
K - Additional Full Coil Coat Protection (Outdoor Unit Only)	Optional	Optional
L - Additional Full Coil Coat Protection (Indoor Unit Only)	Optional	Optional
P - IP44 Rated (Indoor Unit Only)	Optional	Optional
U - Low Ambient + 5°C	Optional	Optional
Y - Powder Coating (Indoor Unit Only)	Optional	Optional

Field Piping and Connections

Factory Charge - (g) Circuit 1 & Circuit 2		12,900 & 12,900	12,830 & 13,330	16,900 & 17,200	13,370 & 13,370	13,330 & 13,830	17,120 & 18,600		
Pre-Charge Length - (m)		N/A	N/A	N/A	5	5	5		
Additional Refrigerant Charge - (g/m)		165	165	165	165	165	220		
Field Pipe Length Range - (m)		20							
Field Pipe Size	Liquid Pipe - mm (inch)	-	-	-	5/8"(15.88)	3/4"(19.05)	5/8"(15.88)	3/4"(19.05)	3/4"(19.05)
	Gas Pipe - mm (inch)	-	-	-	1-1/8" (28.06)	1-1/8" (28.06)	1-3/8" (34.96)	1-1/8" (28.06)	1-3/8" (34.96)
Outdoor Unit	Liquid Pipe - mm (inch)	-	-	-	Ø 15.88mm (5/8") (Swaged)	Ø 19.01mm (3/4") (Swaged)	Ø 19.01mm (3/4") (Swaged)	Ø 19.01mm (3/4") (Swaged)	
	Gas Pipe - mm (inch)	-	-	-	Ø 28.60mm (1-1/8") (Swaged)	Ø 28.60mm (1-1/8") (Swaged)	Ø 28.60mm (1-1/8") (Swaged)	Ø 28.60mm (1-1/8") (Swaged)	
Indoor Unit	Liquid Pipe - mm (inch)	-	-	-	Ø 15.88mm (5/8") (Swaged)	Ø 15.88mm (5/8") (Not Swaged)	Ø 15.88mm (5/8") (Not Swaged)	Ø 15.88mm (5/8") (Not Swaged)	
	Gas Pipe - mm (inch)	-	-	-	Ø 28.60mm (1-1/8") (Swaged)	Ø 28.60 mm (1-1/8") (Swaged)	Ø 28.60 mm (1-1/8") (Swaged)	Ø 28.60 mm (1-1/8") (Swaged)	
Condensation Drain Connection Size - mm (inch)		25.4 (1.0) BSP Female Thread							
Air Duct	Supply Duct H x W - (mm)	1440 x 404	1576 x 462	1576 x 462	699 x 999	800 x 1150	800 x 1150		
	Return Duct H x W - (mm)	1440 x 404	1576 x 462	1576 x 462	932 x 1982	1366 x 1982	1366 x 1982		

Foot Notes 1-14

- Based on unit rating excluding indoor fan kW.
- EER Rated = Energy Efficiency Ratio (Rated Capacity Cooling / Rated Input Cooling).
- COP Rated = Coefficient of Performance (Rated Capacity Heating / Rated Input Heating).
- Refer to AS/NZS 3000 "Australian/New Zealand Wiring Rules" for more details.
- Refer to Catalogue Unit Weight Distribution Guide section for details of weight points.
- Sound Pressure Level at 3m distance is determined as the measured sound pressure at 3m

- perpendicular to the coil side of the condenser. Sound levels are determined in an anechoic chamber and may differ once the unit is installed due to ambient conditions.
- Measured based on ISO 3743-1, Determination of Sound Power Levels and Sound Energy Levels of Noise Sources Using Sound Pressure.
 - Near Field Communications requires compatible device. Provide access to wall control operating instructions
 - Wi-Fi compatibility with 802.11 b/g/n 2.4 GHz



ActronAir

Australian family owned
and operated since 1984

actronair.com.au
1300 522 722

© iPhone, iPod and iPad are registered trademarks of Apple Inc. © Android is a trademark of Google Inc.

ActronAir maintains an unwavering dedication to incessantly enhancing its product offerings in order to uphold the utmost standards of quality and reliability, while simultaneously adhering to local regulations and market demands. The specifications outlined within this document are subject to modification without prior notice, as ActronAir strives to integrate the most recent advancements and innovations into its product line-up for the benefit of its valued customers. It is important to note that the information provided in this brochure is purely informative in nature and should not be utilized as a substitute for the Engineering or Installation Manuals. The cooling and heating capacities referenced for the products represent nominal capacities under standard operating conditions. ActronAir, the brand, hereby absolves itself of any responsibility in the broadcast sense, for any form of damage, whether direct or indirect, that may arise from the utilization and interpretation of the recommendations provided within this document.